

[POWER COMMANDER V]

2011 Kawasaki ZX10

Installation Instructions



PARTS LIST

- 1 Power Commander
- 1 USB Cable
- 1 CD-ROM
- 1 Installation Guide
- 2 Power Commander Decals
- 2 Dynojet Decals
- 2 Velcro
- 1 Alcohol swab
- 1 Posi-tap

**THE IGNITION MUST BE TURNED
OFF BEFORE INSTALLATION!**

YOU CAN ALSO DOWNLOAD THE
POWER COMMANDER SOFTWARE AND
LATEST MAPS FROM OUR WEB SITE AT:
www.powercommander.com

PLEASE READ ALL DIRECTIONS BEFORE STARTING INSTALLATION

Dynojet

2191 Mendenhall Drive North Las Vegas, NV 89081 (800) 992-4993 www.powercommander.com

POWER COMMANDER V INPUT ACCESSORY GUIDE

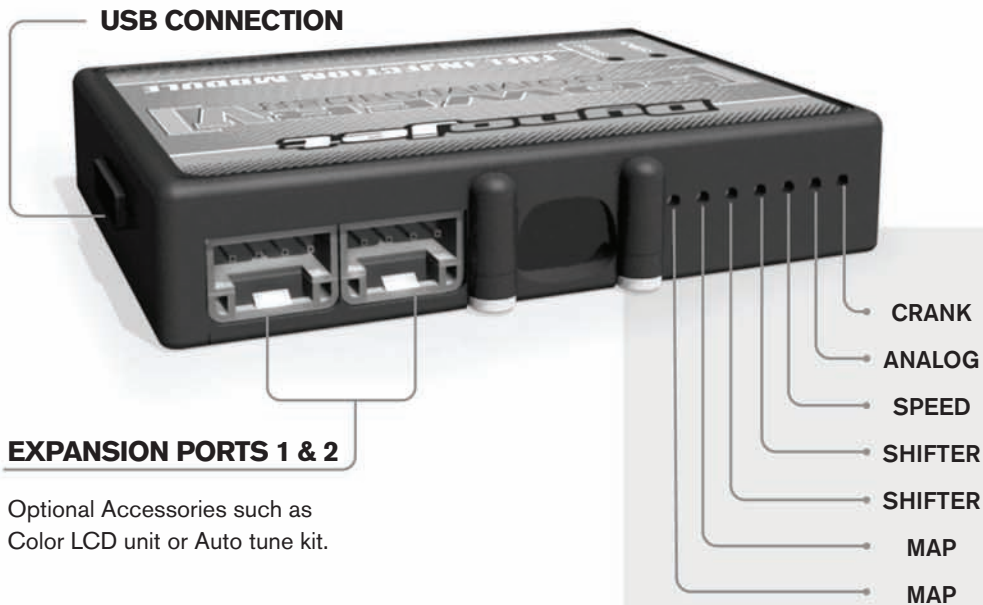

Wire connections:

To input wires into the PCV first remove the rubber plug on the backside of the unit and loosen the screw for the corresponding input. Using a 22-24 gauge wire strip about 10mm from its end. Push the wire into the hole of the PCV until it stops and then tighten the screw. Make sure to reinstall the rubber plug.

NOTE: If you tin the wires with solder it will make inserting them easier.

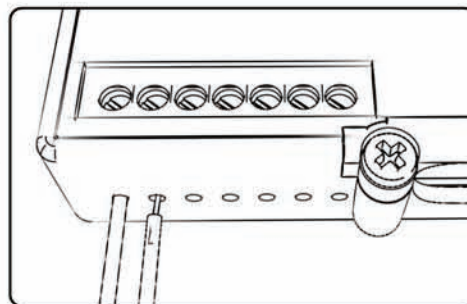

ACCESSORY INPUTS

Map -

The PCV has the ability to hold 2 different base maps. You can switch on the fly between these two base maps when you hook up a switch to the MAP inputs. You can use any open/close type switch. The polarity of the wires is not important. When using the Autotune kit one position will hold a base map and the other position will let you activate the learning mode. When the switch is "CLOSED" Autotune will be activated.

Shifter-

These inputs are for use with the Dynojet quickshifter. Insert the wires from the Dynojet quickshifter into the SHIFTER inputs. The polarity of the wires is not important.

Speed-

If your application has a speed sensor then you can tap into the signal side of the sensor and run a wire into this input. This will allow you to calculate gear position in the Control Center Software. Once gear position is setup you can alter your map based on gear position and setup gear dependent kill times when using a quickshifter.

Analog-

This input is for a 0-5v signal such as engine temp, boost, etc. Once this input is established you can alter your fuel curve based on this input in the control center software.

Crank-

Do **NOT** connect anything to this port unless instructed to do so by Dynojet. It is used to transfer crank trigger data from one module to another.

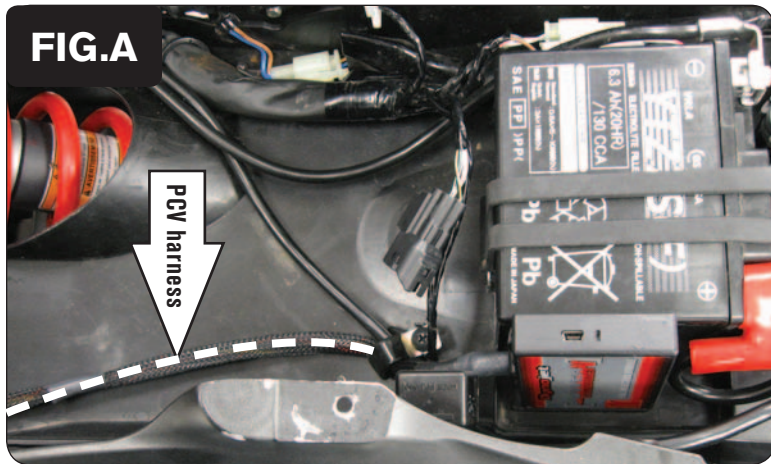

- 1 Remove the main seat and the passenger seat or solo cover.
- 2 Prop the fuel tank up.
- 3 Secure the PCV to the side of the battery using the supplied velcro.
- 4 Route the wiring harness from the PCV towards the engine down the left hand side of the bike (Fig. A).

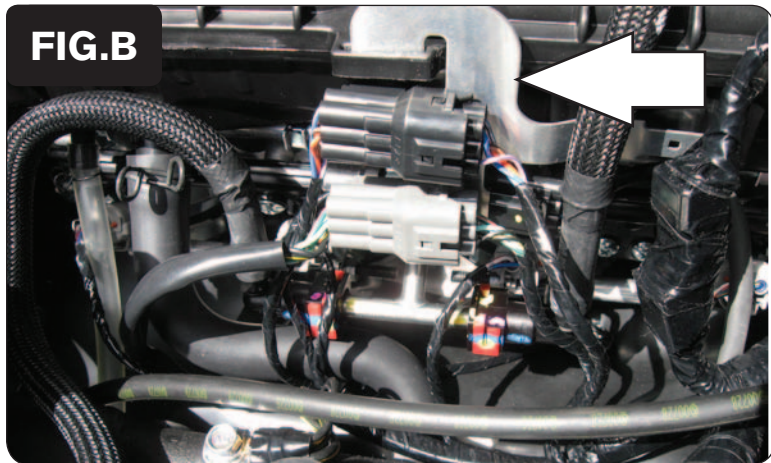

- 5 Slide the bracket on the back of the airbox up to gain access to the injector connectors (Fig. B).

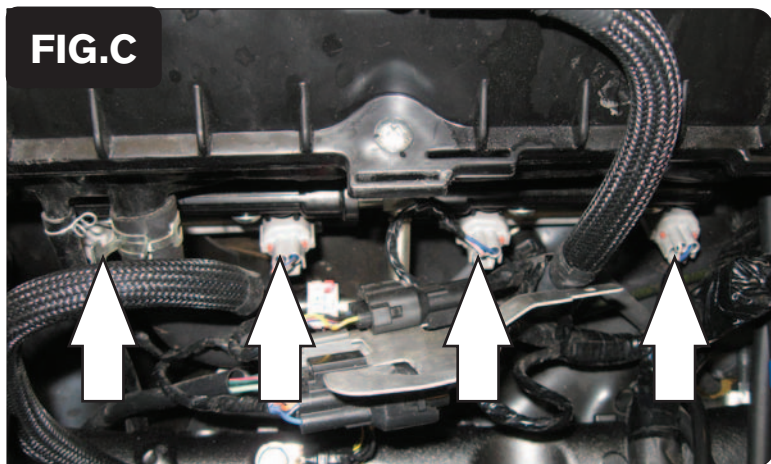

- 6 Unplug the stock wiring harness from each of the LOWER injectors (Fig.C).
The lower injectors are GREY in color.

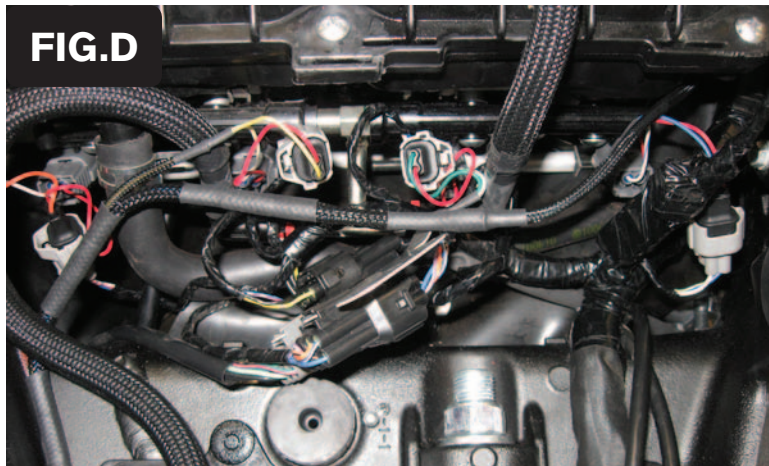

- 7 Connect the PCV harness in-line of the stock injectors and wiring harness (Fig. D).

PCV harness:

ORANGE - cylinder #1

YELLOW - cylinder #2

GREEN - cylinder #3

BLUE - cylinder #4

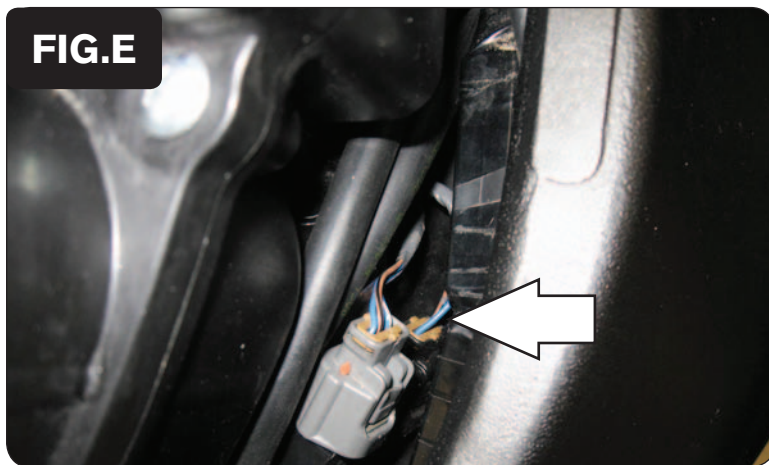

- 8 Locate the Throttle Position Sensor connector on the far right hand side of the throttle bodies (Fig. E).

The TPS connector is the BLACK connector. To access this connector unplug the sensor for the secondary butterflies.

- 9 Unplug the TPS connector and plug the PCV in-line of the stock TPS and wiring harness. Plug the secondary butterfly sensor back onto throttle body.

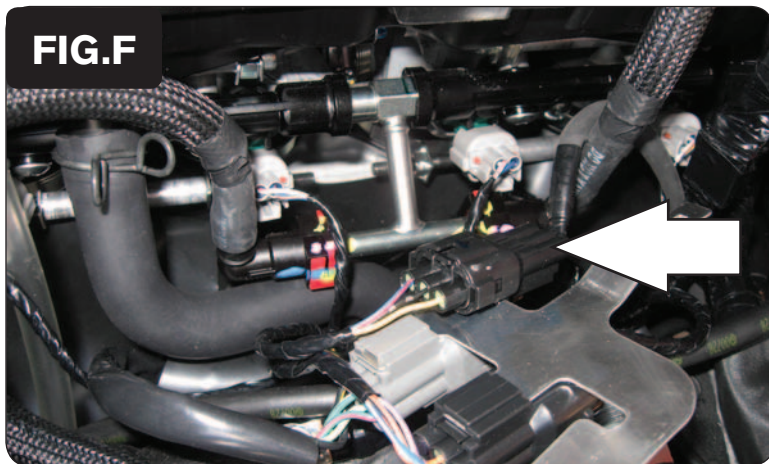

- 10 Locate the crank pickup sensor connector (Fig. F).

This connector is located on the back side of the bracket that was removed in step 5.

- 11 Unplug the crank pickup sensor connector.

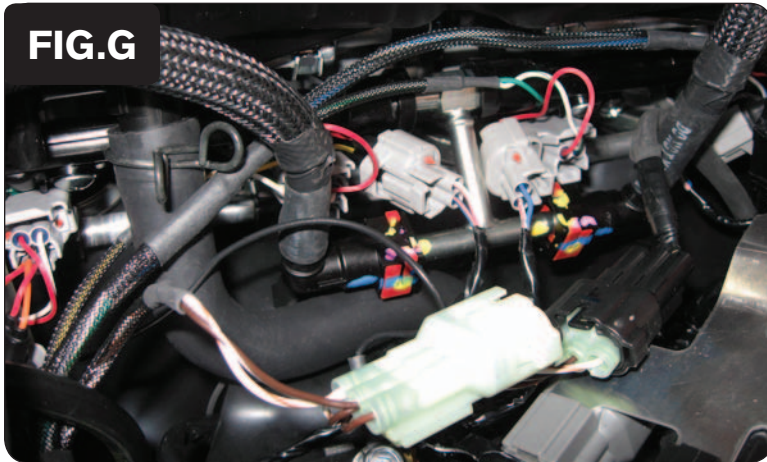

- 12 Plug the connectors from the PCV in-line of the stock crank pickup sensor and stock wiring harness (Fig. G).
- 13 Slide the bracket back onto the rear of the airbox.

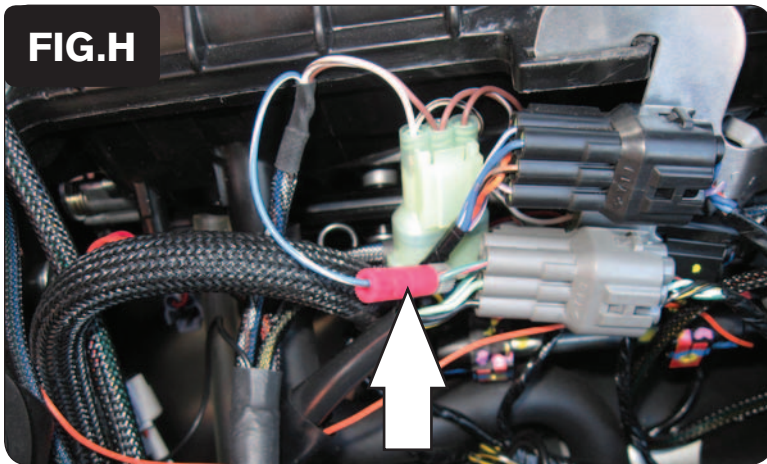

- 14 Attach the BLUE/WHT wire from the PCV to the GRN/RED wire of the stock gear position sensor (Fig. H).

This GREY 6 pin connector is located on the front side of the bracket removed in step 5.

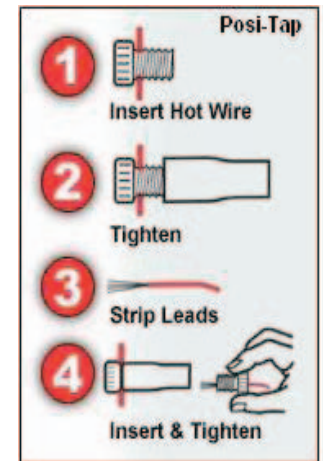

- 15 Attach the ground wire of the PCV to the stock ground location near the top shock mount (Fig. J).
- 16 Reinstall fuel tank and seats.

Temperature input location - ORANGE wire of temperature connector on back of cylinder #3.

12v for Autotune - BLUE/BLACK wire of tail light connector.

