

# [POWER COMMANDER V]

## 2009 Suzuki B-King

### Installation Instructions



#### PARTS LIST

- 1 Power Commander
- 1 USB Cable
- 1 CD-ROM
- 1 Installation Guide
- 2 Power Commander Decals
- 2 Dynojet Decals
- 2 Velcro
- 1 Wire tap
- 1 Alcohol swab
- 1 O2 eliminator

**THE IGNITION MUST BE TURNED OFF BEFORE INSTALLATION!**

YOU CAN ALSO DOWNLOAD THE POWER COMMANDER SOFTWARE AND LATEST MAPS FROM OUR WEB SITE AT:  
[www.powercommander.com](http://www.powercommander.com)

**PLEASE READ ALL DIRECTIONS BEFORE STARTING INSTALLATION**

**Dynojet**

2191 Mendenhall Drive North Las Vegas, NV 89081 (800) 992-4993 [www.powercommander.com](http://www.powercommander.com)

# POWER COMMANDER V INPUT ACCESSORY GUIDE

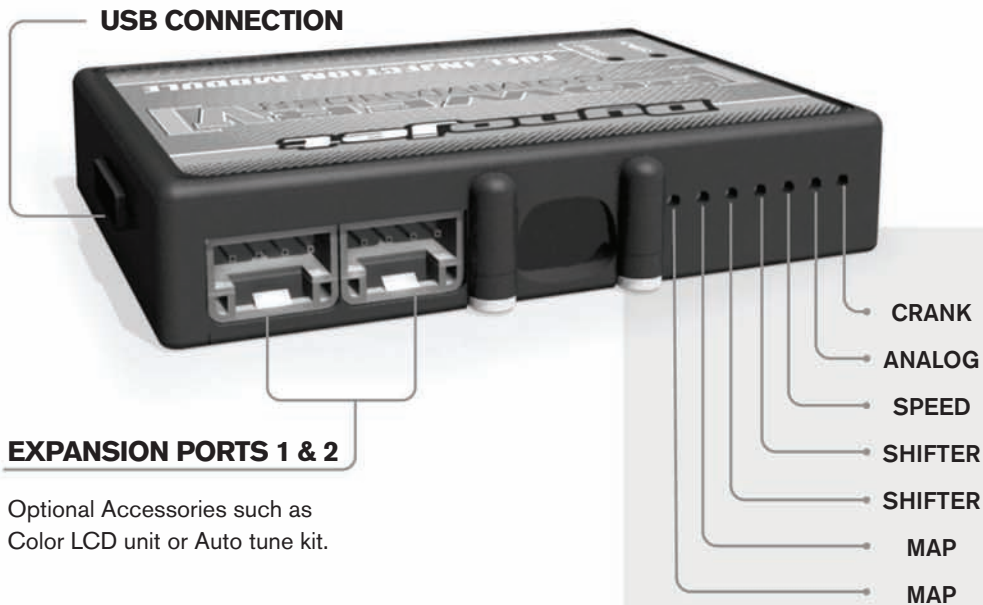

## Wire connections:

To input wires into the PCV first remove the rubber plug on the backside of the unit and loosen the screw for the corresponding input. Using a 22-24 gauge wire strip about 10mm from its end. Push the wire into the hole of the PCV until it stops and then tighten the screw. Make sure to reinstall the rubber plug.

NOTE: If you tin the wires with solder it will make inserting them easier.

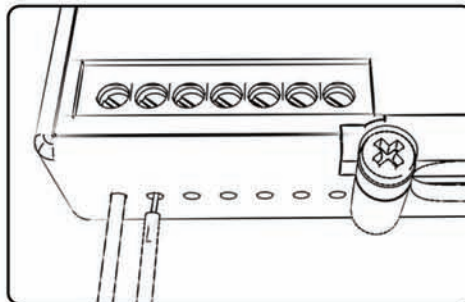

## ACCESSORY INPUTS

### Map -

The PCV has the ability to hold 2 different base maps. You can switch on the fly between these two base maps when you hook up a switch to the MAP inputs. You can use any open/close type switch. The polarity of the wires is not important. When using the Autotune kit one position will hold a base map and the other position will let you activate the learning mode. When the switch is "CLOSED" Autotune will be activated.

### Shifter-

These inputs are for use with the Dynojet quickshifter. Insert the wires from the Dynojet quickshifter into the SHIFTER inputs. The polarity of the wires is not important.

### Speed-

If your application has a speed sensor then you can tap into the signal side of the sensor and run a wire into this input. This will allow you to calculate gear position in the Control Center Software. Once gear position is setup you can alter your map based on gear position and setup gear dependent kill times when using a quickshifter.

### Analog-

This input is for a 0-5v signal such as engine temp, boost, etc. Once this input is established you can alter your fuel curve based on this input in the control center software.

### Crank-

Do **NOT** connect anything to this port unless instructed to do so by Dynojet. It is used to transfer crank trigger data from one module to another.

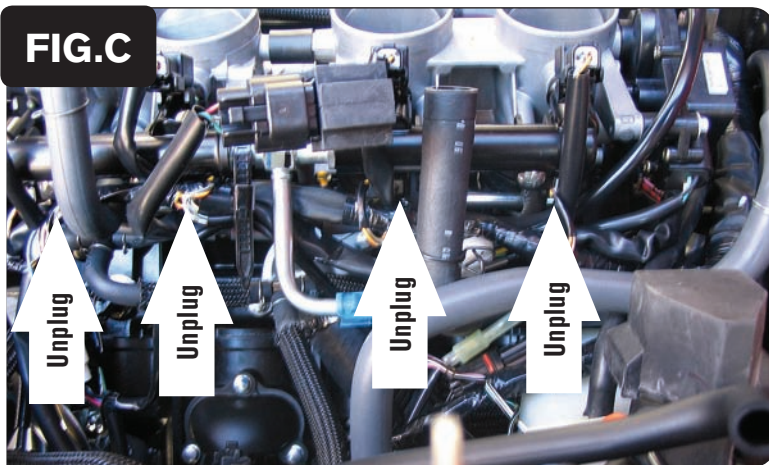
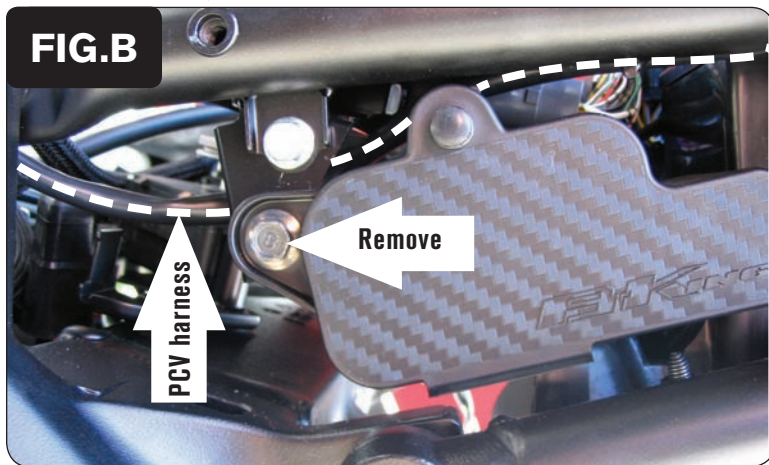
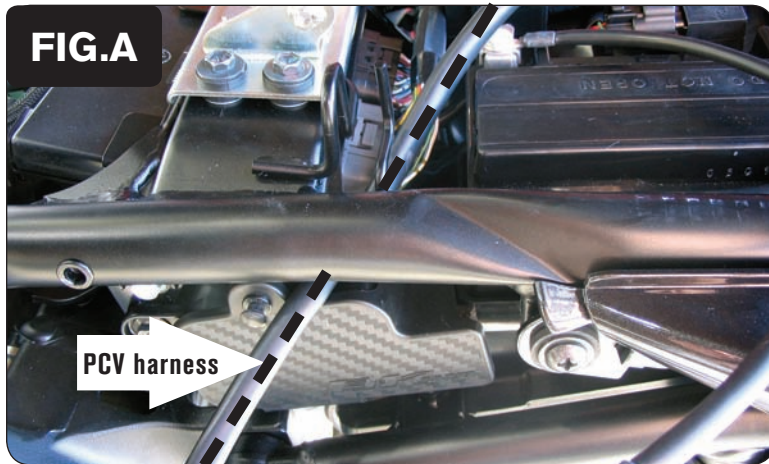

- 1 Remove the main seat and the passenger seat.
- 2 Hold the front of the fuel tank up using the prop rod located in the trunk area.
- 3 Lay the PCV in the tail section and route the PCV harness down the left hand side of the bike towards the throttle bodies.

At the ECU route the PCV harness underneath the left hand frame spar as in Figure A.

- 4 Remove the bolt that holds the tool kit box to the frame (Fig.B).  
*This allows the PCV harness to be routed behind this bracket.*

- 5 Unplug the stock wiring harness from each injector (Fig. C).



6 Plug the PCV wiring harness in-line of the stock wiring harness and injectors (Fig. D).

Cylinder 1 - ORANGE

Cylinder 2 - YELLOW

Cylinder 3 - GREEN

Cylinder 4 - BLUE

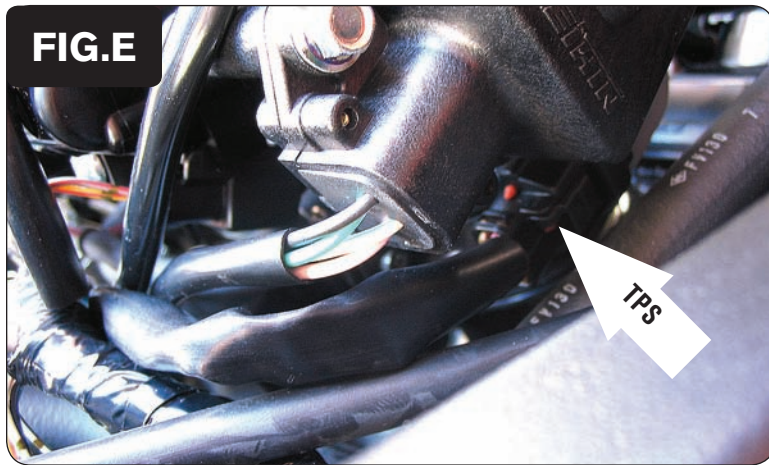

7 Locate the Throttle Position Sensor connector (Fig. E).

*This connector is located on the right hand side of the throttle bodies.*

*Follow the wiring harness of this connector back to where it joins the main wiring harness.*

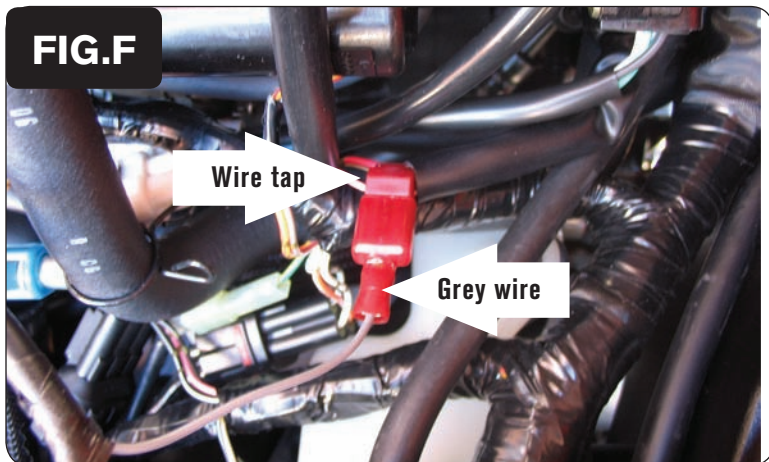

8 Crimp the supplied wire tap to the PINK/BLACK wire of the TPS harness.

9 Connect the GREY wire from the PCV to the wire tap (Fig. F).

*It is recommended to use dielectric grease on these connections.*

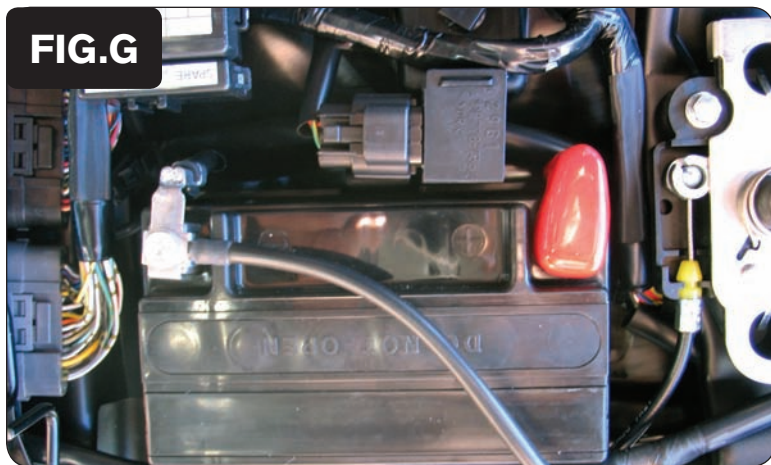

- 9 Attach the ground wire from the PCV to the negative side of the battery (Fig. G).



- 10 Install the PCV in the tail section using the supplied velcro. Make sure to clean both surfaces with the alcohol swab before attaching.
- 11 Locate the stock O2 sensor connection.
- 12 Plug the Dynojet O2 eliminator into the stock wiring harness. The stock O2 sensor will not be connected to anything.
- 13 Bolt fuel tank back into place.

**Speed input** - PINK wire of BLACK 3 pin connector under fuel tank.

**Temperature input** - BLACK/BLUE wire of temperature sensor near #1 throttle body

**12v source for Auto Tune** - BROWN wire of 6 pin connector for tail light.