

[POWER COMMANDER V]

2009 Suzuki Bandit 1250

Installation Instructions



PARTS LIST

- 1 Power Commander
- 1 USB Cable
- 1 CD-ROM
- 1 Installation Guide
- 2 Power Commander Decals
- 2 Dynojet Decals
- 2 Velcro
- 1 Alcohol swab
- 1 O2 eliminator

THE IGNITION MUST BE TURNED OFF BEFORE INSTALLATION!

YOU CAN ALSO DOWNLOAD THE POWER COMMANDER SOFTWARE AND LATEST MAPS FROM OUR WEB SITE AT:
www.powercommander.com

PLEASE READ ALL DIRECTIONS BEFORE STARTING INSTALLATION

Dynojet

2191 Mendenhall Drive North Las Vegas, NV 89081 (800) 992-4993 www.powercommander.com

POWER COMMANDER V INPUT ACCESSORY GUIDE

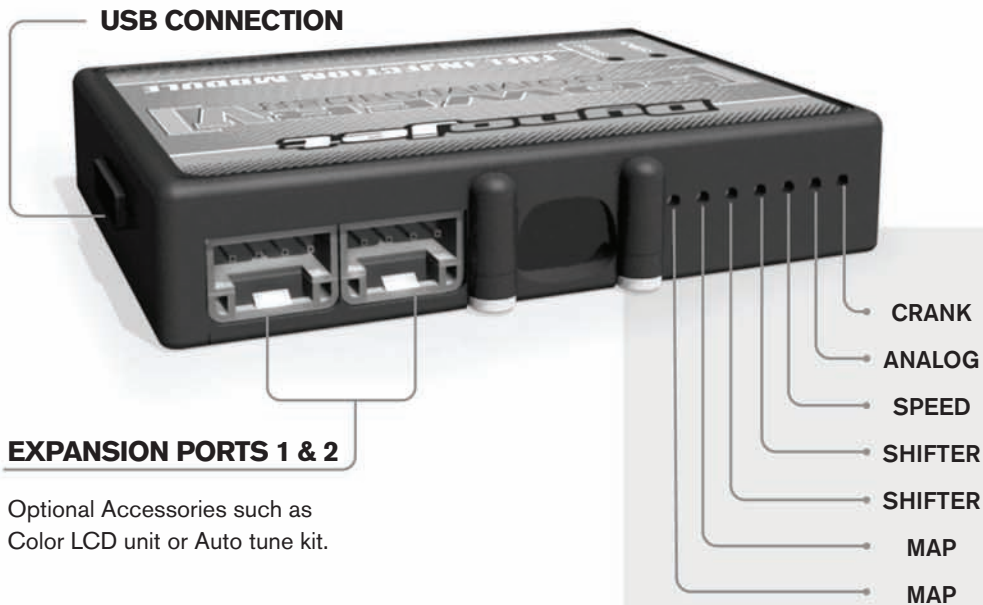

Wire connections:

To input wires into the PCV first remove the rubber plug on the backside of the unit and loosen the screw for the corresponding input. Using a 22-24 gauge wire strip about 10mm from its end. Push the wire into the hole of the PCV until it stops and then tighten the screw. Make sure to reinstall the rubber plug.

NOTE: If you tin the wires with solder it will make inserting them easier.

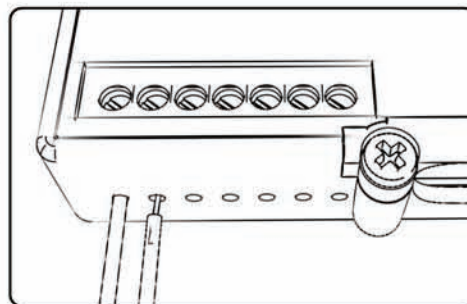

ACCESSORY INPUTS

Map -

The PCV has the ability to hold 2 different base maps. You can switch on the fly between these two base maps when you hook up a switch to the MAP inputs. You can use any open/close type switch. The polarity of the wires is not important. When using the Autotune kit one position will hold a base map and the other position will let you activate the learning mode. When the switch is "CLOSED" Autotune will be activated.

Shifter-

These inputs are for use with the Dynojet quickshifter. Insert the wires from the Dynojet quickshifter into the SHIFTER inputs. The polarity of the wires is not important.

Speed-

If your application has a speed sensor then you can tap into the signal side of the sensor and run a wire into this input. This will allow you to calculate gear position in the Control Center Software. Once gear position is setup you can alter your map based on gear position and setup gear dependent kill times when using a quickshifter.

Analog-

This input is for a 0-5v signal such as engine temp, boost, etc. Once this input is established you can alter your fuel curve based on this input in the control center software.

Crank-

Do **NOT** connect anything to this port unless instructed to do so by Dynojet. It is used to transfer crank trigger data from one module to another.

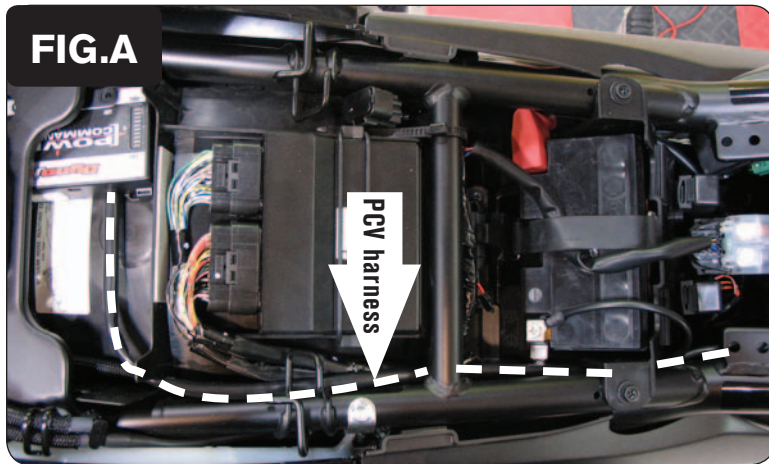

- 1 Remove the seat
- 2 Remove the fuel tank.
- 3 Lay the PCV in the tail section.
- 4 Route the wiring harness from the PCV under subframe crossover and go towards the throttle bodies.

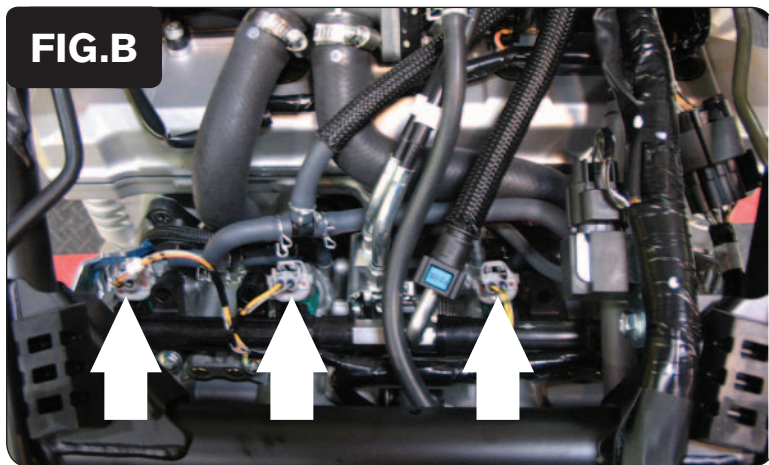

- 5 Unplug the stock wiring harness from each of the injectors (Fig. B).
Injector #4 is hidden in this picture by the main wiring harness.

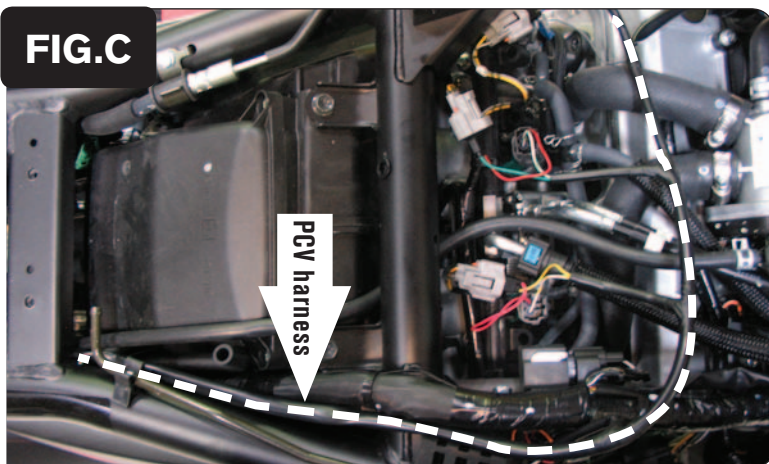

- 6 Plug the connectors from the PCV inline of the stock injectors and the stock wiring harness (Fig.C).

FIG.D

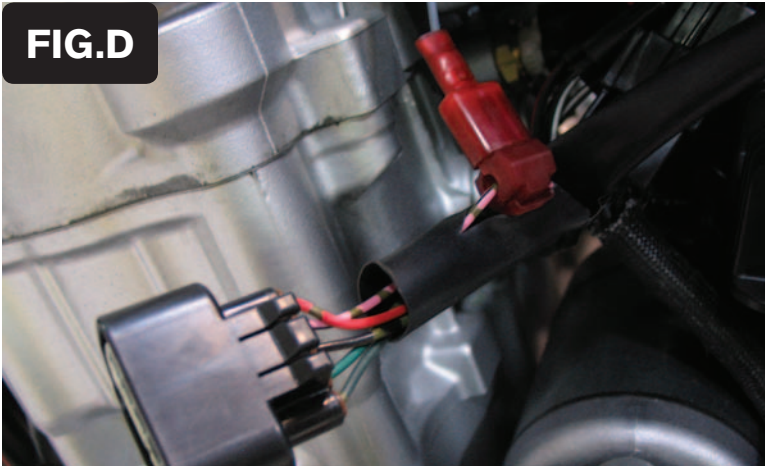

7 Locate the Throttle Position Sensor which is located on the left hand side of the throttle bodies. Unplug this connector to gain access to the wires.

8 Attach the supplied wire tap to the PINK wire with a BLACK stripe (Fig.D).

This connection can be done further up the harness than what is shown in Figure D for a cleaner install.

9 Plug the GREY wire from the PCV into the wire tap (Fig.D).

It is recommended to use dielectric grease on these connections

10 Plug the TPS connector back onto the throttle body..

FIG.E

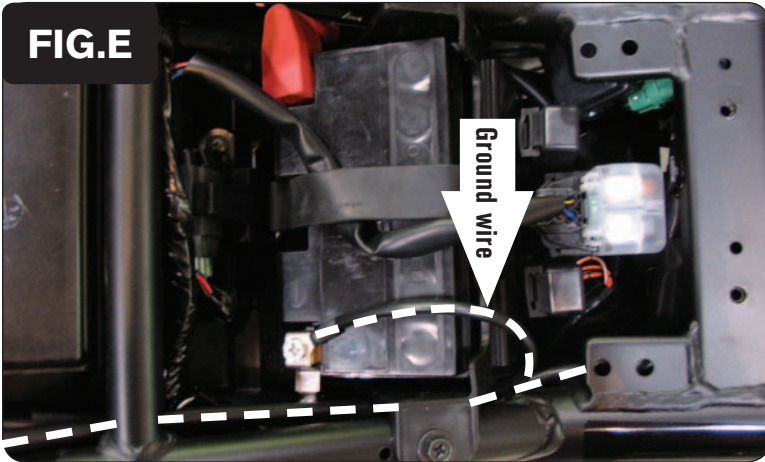

11 Attach the ground wire from the PCV to the negative side of the batter (Fig. E).

12 Reinstall the fuel tank making sure the PCV harness does not get pinched.

13 Secure the PCV in the tail section using the supplied velcro. Make sure to clean both surfaces with the alcohol swab before attaching.

14 Locate the stock O2 sensor under the left hand side cover. Unplug the sensor from stock wiring harness and connect the Dynojet O2 eliminator.

The stock O2 sensor does not need to be connected to anything.