

# [POWER COMMANDER V]

**2009 Suzuki GSX650F**

**Installation Instructions**



## **PARTS LIST**

- 1 Power Commander
- 1 USB Cable
- 1 CD-ROM
- 1 Installation Guide
- 2 Power Commander Decals
- 2 Dynojet Decals
- 2 Velcro
- 1 Alcohol swab

**THE IGNITION MUST BE TURNED  
OFF BEFORE INSTALLATION!**

YOU CAN ALSO DOWNLOAD THE  
POWER COMMANDER SOFTWARE AND  
LATEST MAPS FROM OUR WEB SITE AT:  
[www.powercommander.com](http://www.powercommander.com)

**PLEASE READ ALL DIRECTIONS BEFORE STARTING INSTALLATION**

**Dynojet**

2191 Mendenhall Drive North Las Vegas, NV 89081 (800) 992-4993 [www.powercommander.com](http://www.powercommander.com)

# POWER COMMANDER V INPUT ACCESSORY GUIDE

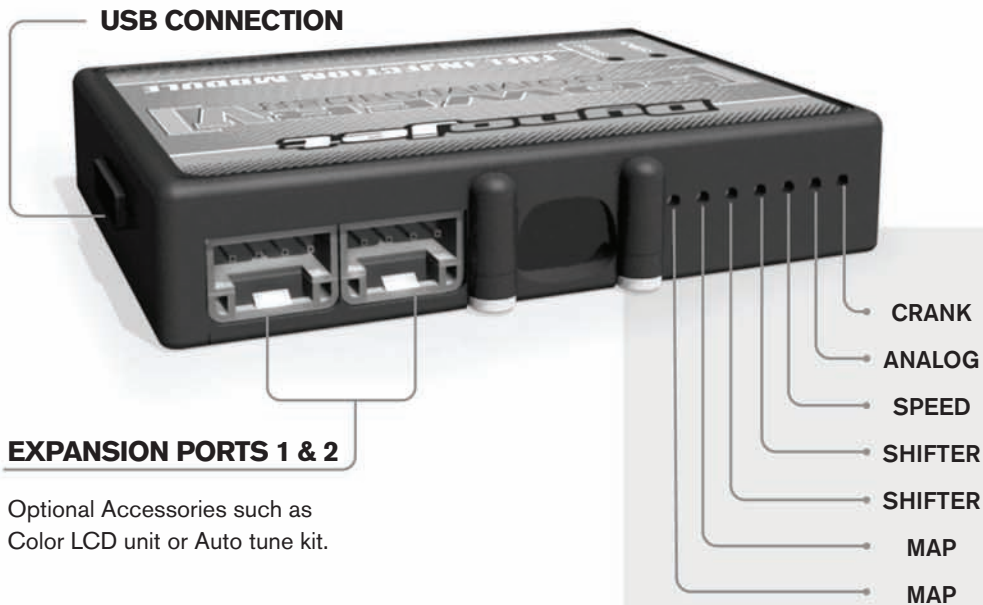

## Wire connections:

To input wires into the PCV first remove the rubber plug on the backside of the unit and loosen the screw for the corresponding input. Using a 22-24 gauge wire strip about 10mm from its end. Push the wire into the hole of the PCV until it stops and then tighten the screw. Make sure to reinstall the rubber plug.

NOTE: If you tin the wires with solder it will make inserting them easier.

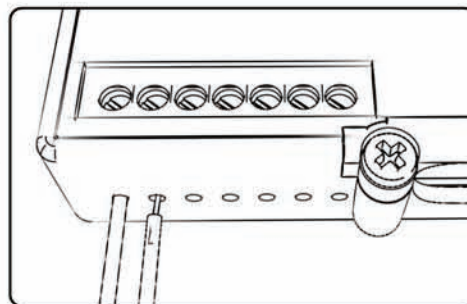

## ACCESSORY INPUTS

### Map -

The PCV has the ability to hold 2 different base maps. You can switch on the fly between these two base maps when you hook up a switch to the MAP inputs. You can use any open/close type switch. The polarity of the wires is not important. When using the Autotune kit one position will hold a base map and the other position will let you activate the learning mode. When the switch is "CLOSED" Autotune will be activated.

### Shifter-

These inputs are for use with the Dynojet quickshifter. Insert the wires from the Dynojet quickshifter into the SHIFTER inputs. The polarity of the wires is not important.

### Speed-

If your application has a speed sensor then you can tap into the signal side of the sensor and run a wire into this input. This will allow you to calculate gear position in the Control Center Software. Once gear position is setup you can alter your map based on gear position and setup gear dependent kill times when using a quickshifter.

### Analog-

This input is for a 0-5v signal such as engine temp, boost, etc. Once this input is established you can alter your fuel curve based on this input in the control center software.

### Crank-

Do **NOT** connect anything to this port unless instructed to do so by Dynojet. It is used to transfer crank trigger data from one module to another.

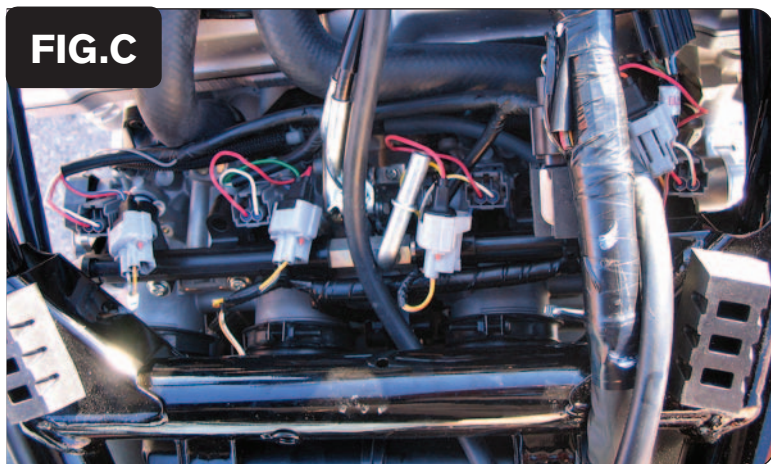
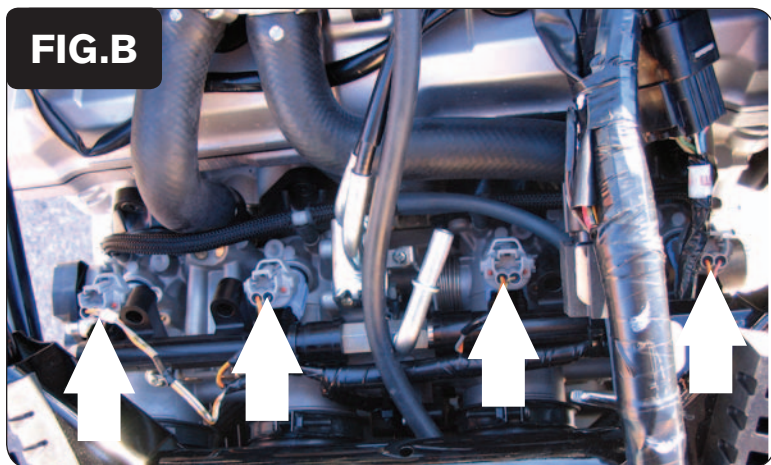
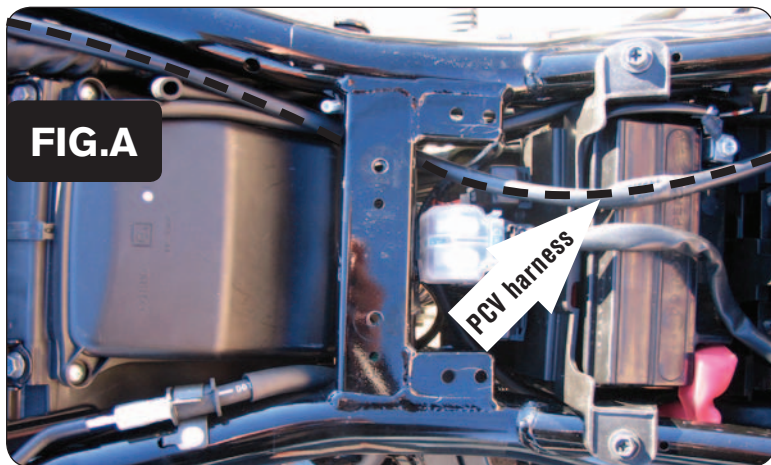

- 1 Remove the seat and left hand side cover.
  - 2 Remove the fuel tank.
  - 3 Lay the PCV in the tail section.
  - 4 Route the wiring harness from the PCV under the frame crossover and go towards the engine along the right hand side of the air box (Fig. A).
  - 5 Unplug the stock wiring harness from each of the injectors (Fig. B).
  - 6 Plug the connectors from the PCV inline of the stock injectors and the stock wiring harness (Fig.C).
- PCV colors:
- BLUE - cylinder #1
  - GREEN - cylinder #2
  - YELLOW - cylinder #3
  - ORANGE - cylinder #4

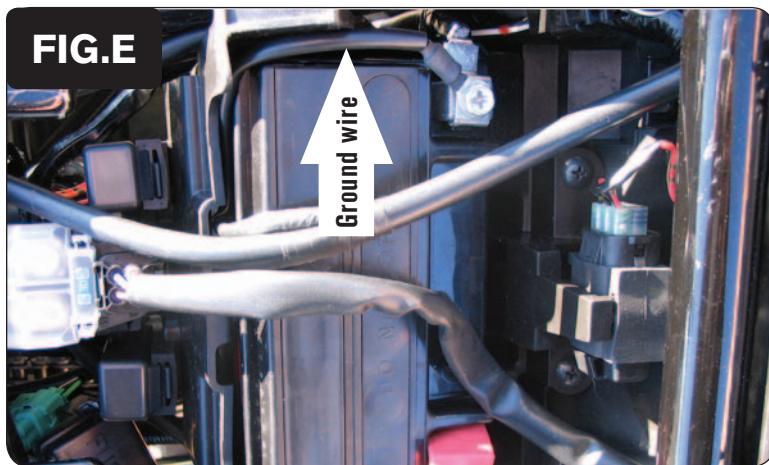
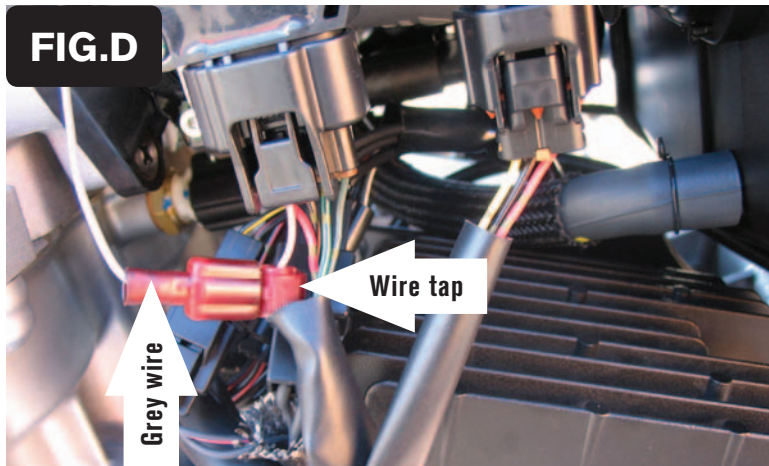

- 7 Locate the Throttle Position Sensor which is located on the left hand side of the throttle bodies. This is the 5 pin connector.
- 8 Attach the supplied wire tap (or Posi-tap) to the PINK wire with a BLACK stripe (Fig.D).
- 9 Plug the grey wire from the PCV into the wire tap (Fig.D).

*It is recommended to use dielectric grease on these connections.*

*For a cleaner look you can follow the TPS wire back to a junction where you can hide the wire tap easier.*

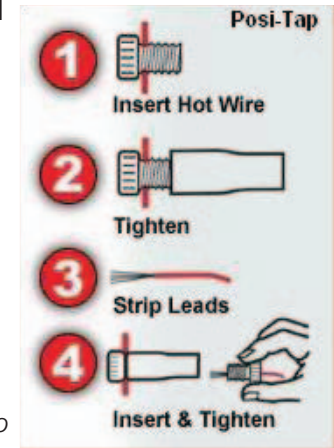

- 10 Attach the ground wire from the PCV to the negative side of the battery (Fig. E).

- 11 Install the PCV in the tail section to the inner fender. Use the supplied velcro to attach the unit (Fig. F).

*Make sure to clean both surfaces with the alcohol swab before attaching.*

**FIG.G**



- 12 Locate the stock O2 sensor connection.

*This is a BLACK 4 pin connector located on the left hand side of the frame next to the fuse box.*

- 13 Unplug this connection and plug the Dynojet O2 eliminator into the stock wiring harness (Fig. G).

*The stock O2 sensor will not be connected to anything.*

- 14 Reinstall the fuel tank, side cover and seat.

**Speed input** - BLACK wire of speed sensor. Connector is behind the left side panel near the O2 sensor connection.

**Temperature input** - BLK/BLU wire of temperature sensor on backside of cylinder between #1 & #2.

**12v source for Auto tune** - GREY wire of tail light plug.