

[POWER COMMANDER V]

2011 Triumph Speed Triple

Installation Instructions



PARTS LIST

- 1 Power Commander
- 1 USB Cable
- 1 CD-ROM
- 1 Installation Guide
- 2 Power Commander Decals
- 2 Dynojet Decals
- 2 Velcro
- 1 Alcohol swab
- 1 O2 Optimizer

THE IGNITION MUST BE TURNED OFF BEFORE INSTALLATION!

YOU CAN ALSO DOWNLOAD THE POWER COMMANDER SOFTWARE AND LATEST MAPS FROM OUR WEB SITE AT:
www.powercommander.com

PLEASE READ ALL DIRECTIONS BEFORE STARTING INSTALLATION

Dynojet

2191 Mendenhall Drive North Las Vegas, NV 89081 (800) 992-4993 www.powercommander.com

POWER COMMANDER V INPUT ACCESSORY GUIDE

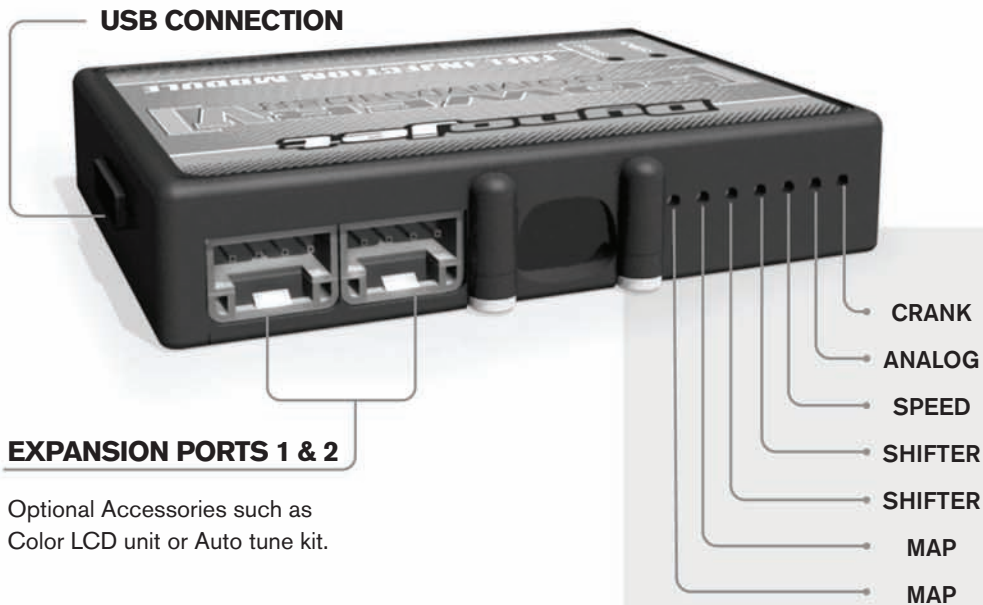

Wire connections:

To input wires into the PCV first remove the rubber plug on the backside of the unit and loosen the screw for the corresponding input. Using a 22-24 gauge wire strip about 10mm from its end. Push the wire into the hole of the PCV until it stops and then tighten the screw. Make sure to reinstall the rubber plug.

NOTE: If you tin the wires with solder it will make inserting them easier.

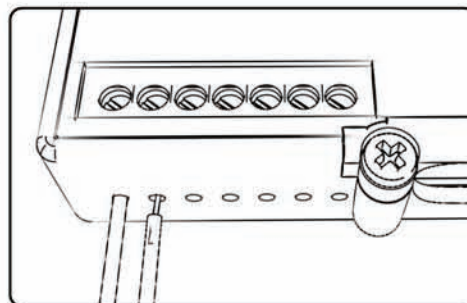

ACCESSORY INPUTS

Map -

The PCV has the ability to hold 2 different base maps. You can switch on the fly between these two base maps when you hook up a switch to the MAP inputs. You can use any open/close type switch. The polarity of the wires is not important. When using the Autotune kit one position will hold a base map and the other position will let you activate the learning mode. When the switch is "CLOSED" Autotune will be activated.

Shifter-

These inputs are for use with the Dynojet quickshifter. Insert the wires from the Dynojet quickshifter into the SHIFTER inputs. The polarity of the wires is not important.

Speed-

If your application has a speed sensor then you can tap into the signal side of the sensor and run a wire into this input. This will allow you to calculate gear position in the Control Center Software. Once gear position is setup you can alter your map based on gear position and setup gear dependent kill times when using a quickshifter.

Analog-

This input is for a 0-5v signal such as engine temp, boost, etc. Once this input is established you can alter your fuel curve based on this input in the control center software.

Crank-

Do **NOT** connect anything to this port unless instructed to do so by Dynojet. It is used to transfer crank trigger data from one module to another.

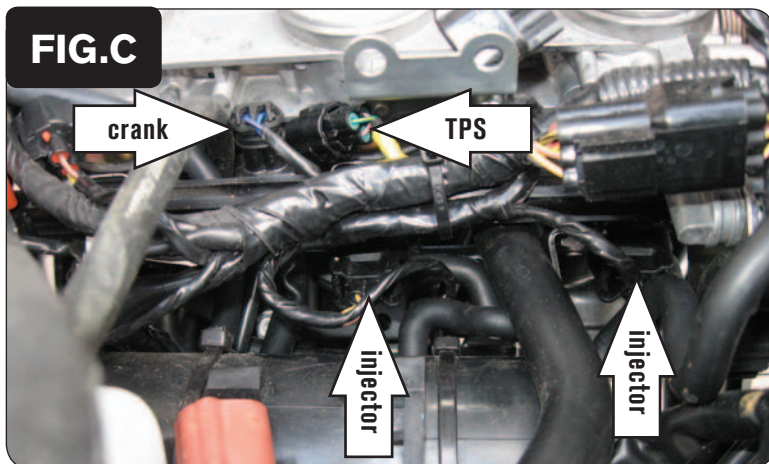
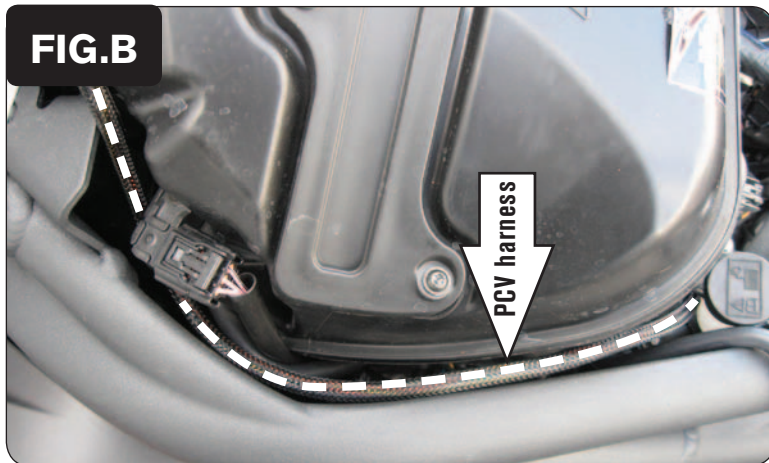
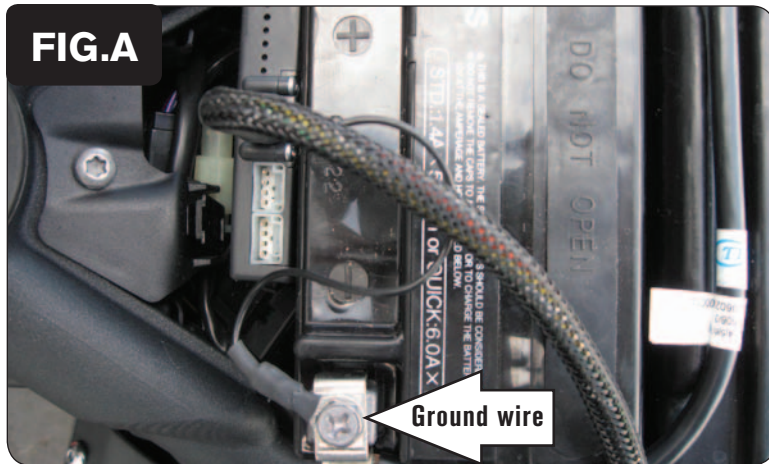

- 1 Remove the seat.
- 2 Remove the fuel tank
Removing the air box MAY make accessing the some of the connectors easier but is NOT necessary to remove.
- 3 Secure the PCV to the front of the battery using the supplied velcro (Fig. A). Make sure to use the alcohol swab to clean both surfaces before attaching.
- 4 Attach the ground wire of the PCV to the negative side of the battery (Fig A).
- 5 Route the PCV harness down the left side of the air box and go towards the throttle bodies (Fig. B).
- 6 Disconnect the stock wiring harness from each connector per Figure C:
Crank sensor - 2 pin connector located between #1 & #2 throttle body
Throttle Position Sensor - 3 pin connector next to crank connector
Each injector connector - (#1 injector not shown in Figure. C)

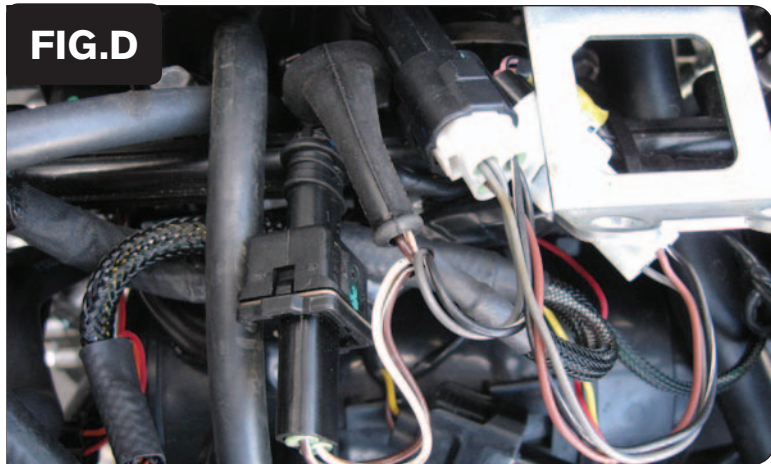

- 7 Connect the PCV harness in-line of the stock crank sensor and stock wiring harness (Fig. D).
- 8 Connect the PCV harness in-line of the stock TPS connector and stock wiring harness (Fig. D).

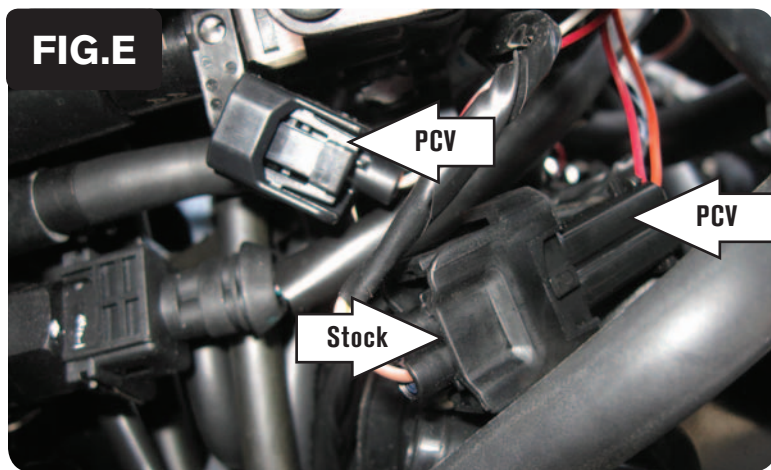

- 9 Plug the PCV harness in-line of the stock wiring harness and each injector
PCV harness:
ORANGE - cylinder #1 (left)
YELLOW - cylinder #2
GREEN - cylinder #3
Figure E shows the #1 cylinder. Repeat this for the other 2 cylinders.

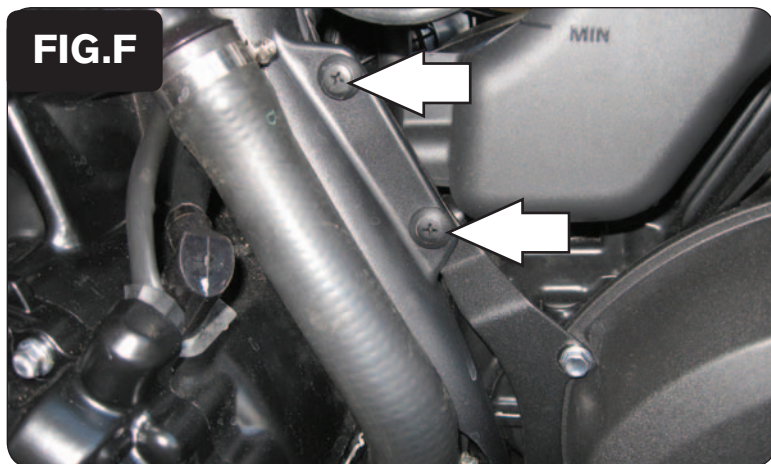

- 10 Remove the plastic cover on the left side of the engine (Fig. F).

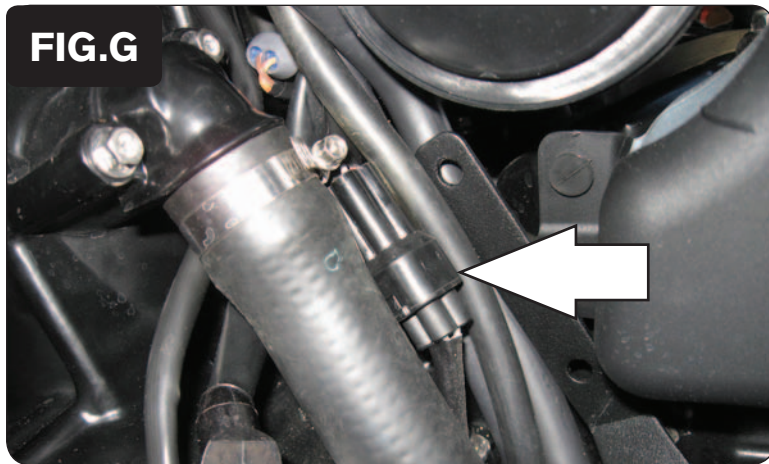

- 11 Locate the stock O2 sensor connection and unplug it (Fig. G).
This is a BLACK 4 pin connector.

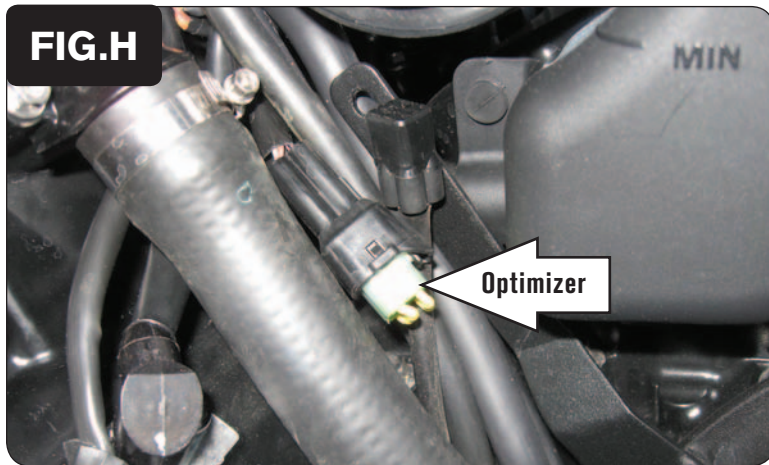

- 12 Plug the Dynojet O2 Optimizer into the stock wiring harness (Fig. H).
The stock O2 sensor will no longer be connected to anything.
- 13 Reinstall the plastic cover.
- 14 Reinstall the fuel tank and seat.