

[POWER COMMANDER V]

2009-2010 Yamaha FZ6

Installation Instructions



PARTS LIST

- 1 Power Commander
- 1 USB Cable
- 1 CD-ROM
- 1 Installation Guide
- 2 Power Commander Decals
- 2 Dynojet Decals
- 2 Velcro
- 1 Alcohol swab
- 1 Posi-tap
- 1 Wire

THE IGNITION MUST BE TURNED OFF BEFORE INSTALLATION!

YOU CAN ALSO DOWNLOAD THE POWER COMMANDER SOFTWARE AND LATEST MAPS FROM OUR WEB SITE AT:
www.powercommander.com

PLEASE READ ALL DIRECTIONS BEFORE STARTING INSTALLATION

Dynojet

2191 Mendenhall Drive North Las Vegas, NV 89081 (800) 992-4993 www.powercommander.com

POWER COMMANDER V INPUT ACCESSORY GUIDE

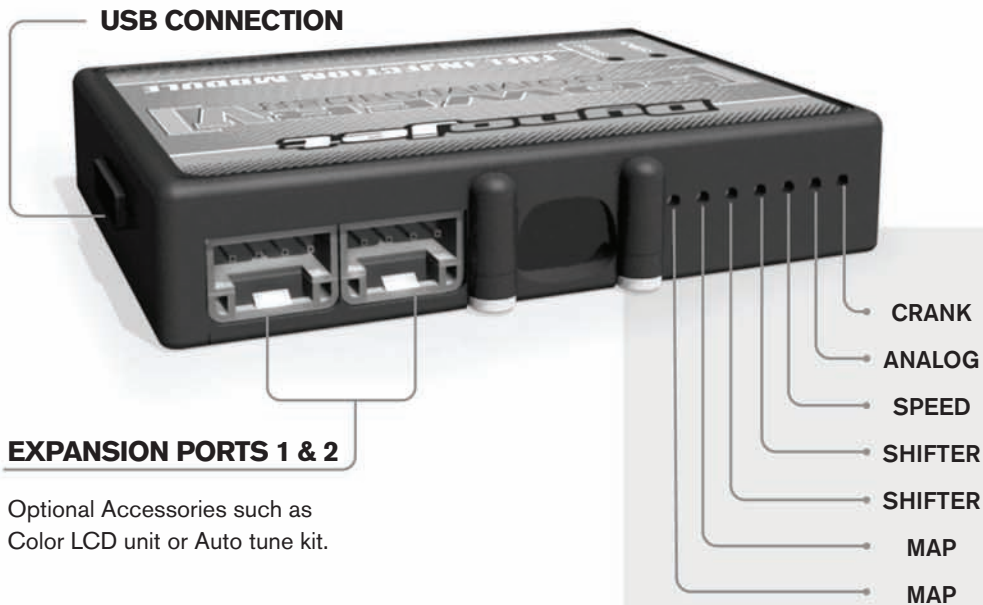

Wire connections:

To input wires into the PCV first remove the rubber plug on the backside of the unit and loosen the screw for the corresponding input. Using a 22-24 gauge wire strip about 10mm from its end. Push the wire into the hole of the PCV until it stops and then tighten the screw. Make sure to reinstall the rubber plug.

NOTE: If you tin the wires with solder it will make inserting them easier.

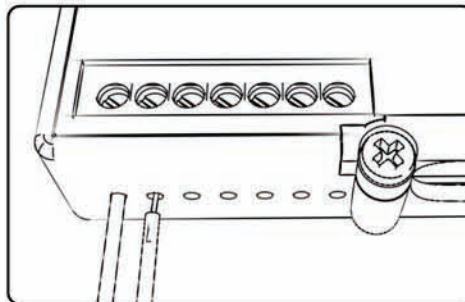

ACCESSORY INPUTS

Map -

The PCV has the ability to hold 2 different base maps. You can switch on the fly between these two base maps when you hook up a switch to the MAP inputs. You can use any open/close type switch. The polarity of the wires is not important. When using the Autotune kit one position will hold a base map and the other position will let you activate the learning mode. When the switch is "CLOSED" Autotune will be activated.

Shifter-

These inputs are for use with the Dynojet quickshifter. Insert the wires from the Dynojet quickshifter into the SHIFTER inputs. The polarity of the wires is not important.

Speed-

If your application has a speed sensor then you can tap into the signal side of the sensor and run a wire into this input. This will allow you to calculate gear position in the Control Center Software. Once gear position is setup you can alter your map based on gear position and setup gear dependent kill times when using a quickshifter.

Analog-

This input is for a 0-5v signal such as engine temp, boost, etc. Once this input is established you can alter your fuel curve based on this input in the control center software.

Crank-

Do **NOT** connect anything to this port unless instructed to do so by Dynojet. It is used to transfer crank trigger data from one module to another.

FIG.A



- 1 Remove the main seat and the passenger seat.
- 2 Prop the front of fuel tank up.
(Figure A shown with fuel tank removed which is not necessary)
- 3 Lay the PCV unit in the tail section and route the harness down the left side of the bike (Fig. A)

FIG.B

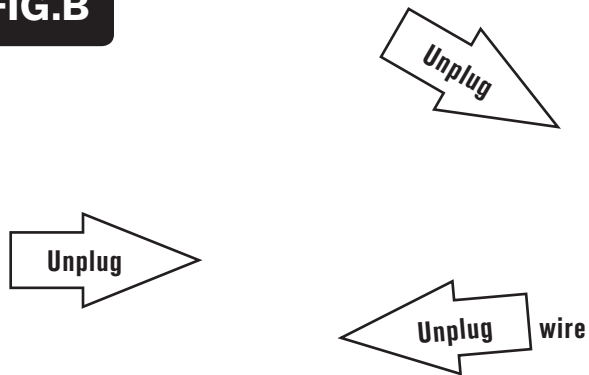

- 4 Unplug the wiring harness from the throttle bodies (Fig. B).
One connector is a WHITE 4 pin and the other is a CLEAR 6 pin.
- 5 Unplug the O2 sensor from the main wiring harness (Fig. B).
The stock O2 sensor will no longer be connected to anything.

FIG.C



- 6 Plug the connectors from the PCV in-line of the stock wiring harness (Fig. C).

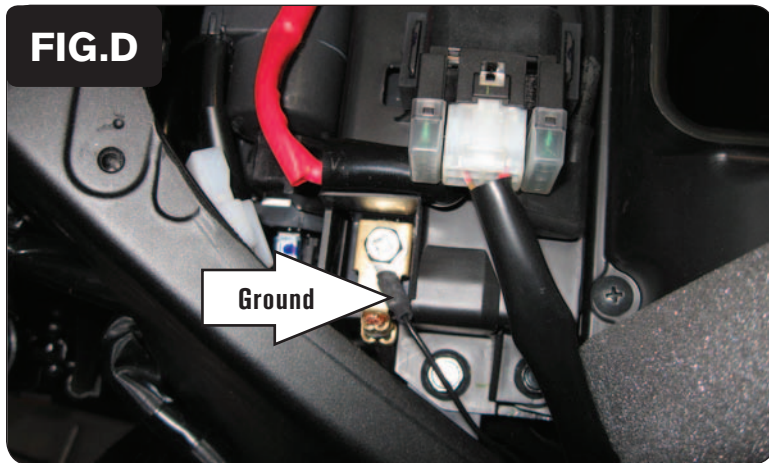

- 7 Attach the ground wire of the PCV to the negative side of the battery (Fig. D).



- 8 Secure the PCV unit in the tail section using the supplied velcro (Fig. E).
Make sure to clean both surfaces with the alcohol swab before attaching

Temperature input - Green/White wire of 6 pin clear connector under fuel tank
(Same as PCV connection).

12v source for Auto tune - BLUE wire of tail light connector.

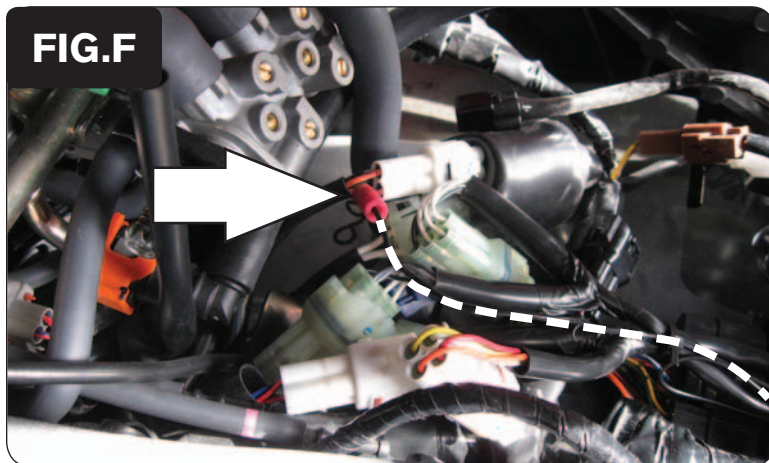

- 9 On this bike it is highly recommended to connect the PCV to the speed input so that the map can be put into advanced mode. To do this, use the supplied piece of wire and posi-tap and connect to the PINK wire of 3 pin WHITE connector under fuel tank (Fig. F).
- 10 Connect the other end of the wire into the PCV - see page 2.
- 11 Bolt the fuel tank back into place and reinstall the seats.