

[POWER COMMANDER V]

2010 Yamaha R6

Installation Instructions



PARTS LIST

- 1 Power Commander
- 1 USB Cable
- 1 CD-ROM
- 1 Installation Guide
- 2 Power Commander Decals
- 2 Dynojet Decals
- 2 Velcro
- 1 Alcohol swab
- 1 Posi-tap
- 1 O2 optimizer

THE IGNITION MUST BE TURNED OFF BEFORE INSTALLATION!

YOU CAN ALSO DOWNLOAD THE POWER COMMANDER SOFTWARE AND LATEST MAPS FROM OUR WEB SITE AT:
www.powercommander.com

PLEASE READ ALL DIRECTIONS BEFORE STARTING INSTALLATION

Dynojet

2191 Mendenhall Drive North Las Vegas, NV 89081 (800) 992-4993 www.powercommander.com

POWER COMMANDER V INPUT ACCESSORY GUIDE

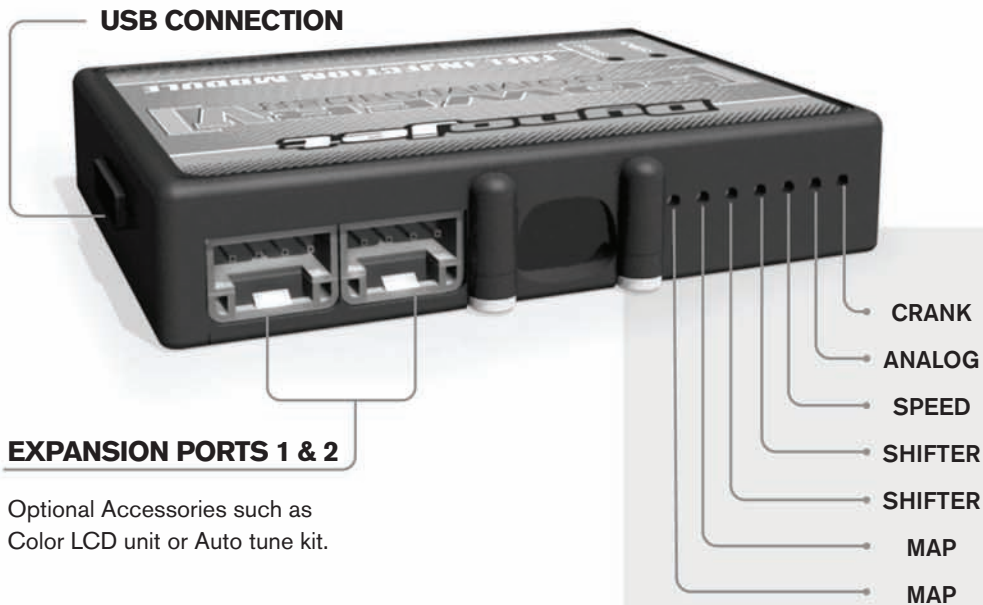

Optional Accessories such as Color LCD unit or Auto tune kit.

Wire connections:

To input wires into the PCV first remove the rubber plug on the backside of the unit and loosen the screw for the corresponding input. Using a 22-24 gauge wire strip about 10mm from its end. Push the wire into the hole of the PCV until it stops and then tighten the screw. Make sure to reinstall the rubber plug.

NOTE: If you tin the wires with solder it will make inserting them easier.

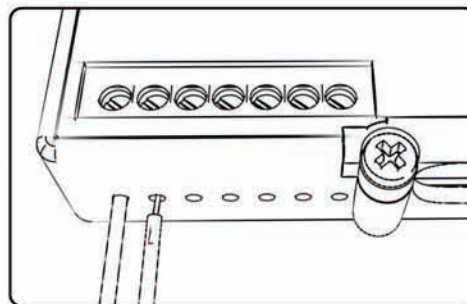

ACCESSORY INPUTS

Map -

The PCV has the ability to hold 2 different base maps. You can switch on the fly between these two base maps when you hook up a switch to the MAP inputs. You can use any open/close type switch. The polarity of the wires is not important. When using the Autotune kit one position will hold a base map and the other position will let you activate the learning mode. When the switch is "CLOSED" Autotune will be activated.

Shifter-

These inputs are for use with the Dynojet quickshifter. Insert the wires from the Dynojet quickshifter into the SHIFTER inputs. The polarity of the wires is not important.

Speed-

If your application has a speed sensor then you can tap into the signal side of the sensor and run a wire into this input. This will allow you to calculate gear position in the Control Center Software. Once gear position is setup you can alter your map based on gear position and setup gear dependent kill times when using a quickshifter.

Analog-

This input is for a 0-5v signal such as engine temp, boost, etc. Once this input is established you can alter your fuel curve based on this input in the control center software.

Crank-

Do **NOT** connect anything to this port unless instructed to do so by Dynojet. It is used to transfer crank trigger data from one module to another.

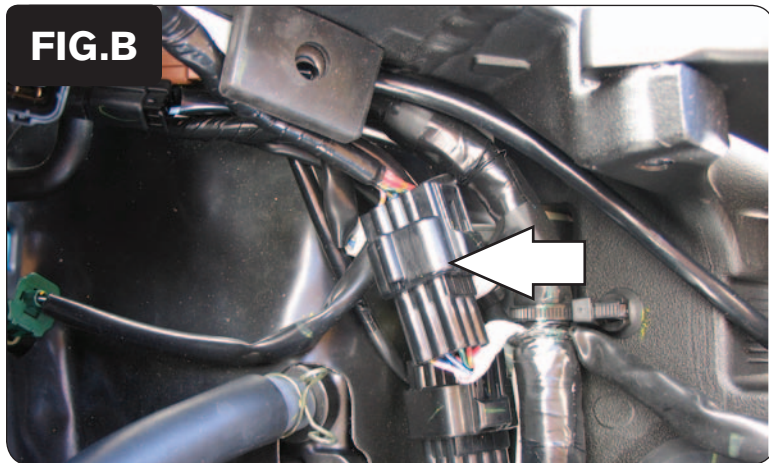
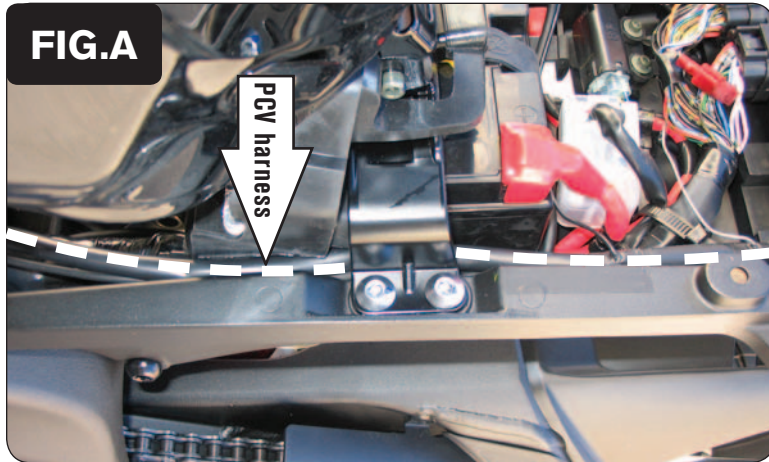

- 1 Remove the main seat.
- 2 Prop the front of the fuel tank up.
- 3 Route the PCV harness down the left hand side of the bike. Route the PCV harness underneath the fuel tank bracket (Fig. A). The bolts that hold the fuel tank bracket will need to be loosened to allow room for the PCV harness to fit underneath. Tighten these bolts after the installation is complete.

- 4 Unplug the connector from the throttle bodies to the main wiring harness (Fig. B). This is the 9 pin BLACK connector.

- 5 Plug the PCV connectors in-line of the stock connector (Fig. C).

Make sure these connectors are positioned as to not interfere with the fuel line when the fuel tank is installed back into position.

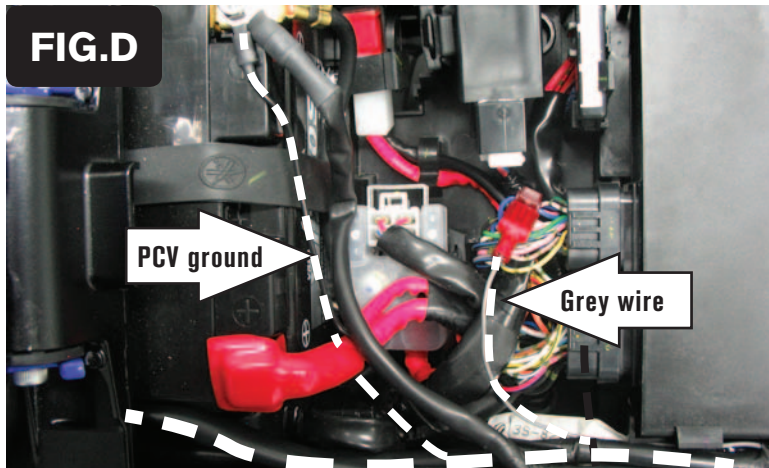

- 6 Attach the ground wire from the PCV to the negative side of the battery (Fig. D).

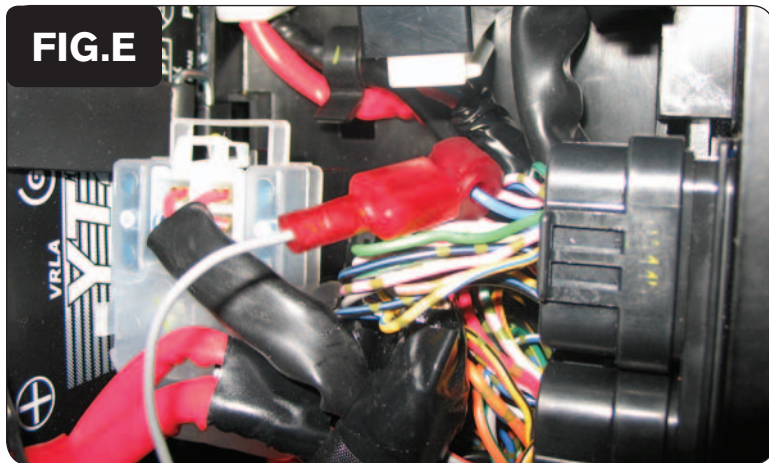

- 7 Using the supplied posi-tap attach the GREY wire of the PCV to the BLUE wire of the ECU (Fig. E).

This is pin #5 on the smaller ECU connector. The back of the connector is numbered for reference.

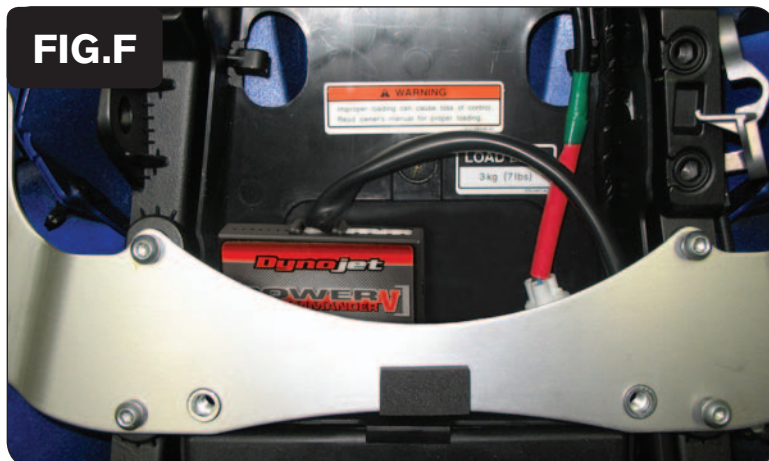
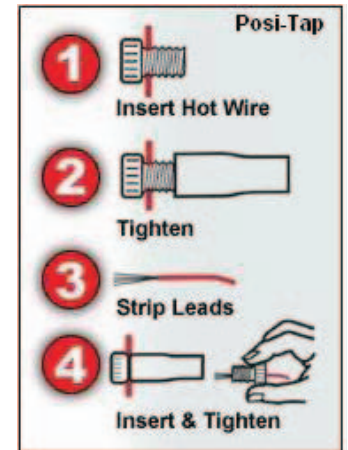

- 8 Install the PCV in the tail section of the bike using the supplied velcro (Fig. F). It is recommended to route the PCV harness underneath the subframe bracket. Make sure to use the alcohol swab to clean both surfaces before attaching velcro.

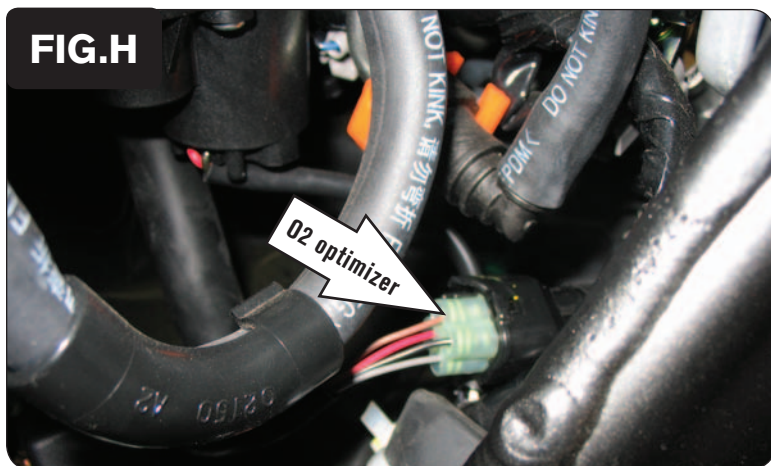
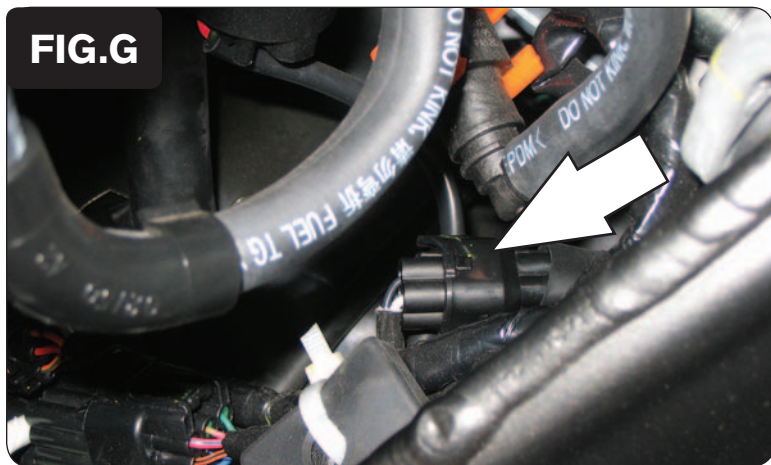

- 9 Locate the stock O2 sensor connection.

This is located under the fuel tank near the right hand side of the frame. It is a BLACK 4 pin connector.

- 10 Unplug the stock O2 sensor from the main wiring harness (Fig. G).

- 11 Plug the Dynojet O2 optimizer into the main wiring harness.

The optimizer can lay on top of the engine or be securely fastened to the harness.

Make sure it does not come into contact with the fuel tank when it is in place.

Temperature input - Temperature sensor is located on back of cylinder near #3 throttle body. GRN/WHT wire to ECU. Pin #25 on small ECU connector

12v source - BLU/RED wire of tail light connector.

Speed input - Top of engine case on left hand side. PINK wire on sensor side - WHT/YEL wire on ECU side.

Tuning Notes:

This bike uses a fly-by wire system, so conventional tuning can not be performed for all RPM and throttle ranges.

The GREY wire from the PCV is attached to the throttle blade angle sensor of the throttle bodies which is NOT directly correlated to the throttle grip position. Because of this when setting the throttle position in the PCV software we recommend on resetting only the closed position after the bike has completely warmed up. Use the arrow key (<) next to CLOSED to perform this step and then click OK. Do not try to set the OPEN position unless you are on a dyno and above 11000rpm.

You will notice that in the maps there are not detailed values below 10500rpm at 60-100%. This is because the throttle blades will not open more than 60% below this RPM range no matter how much throttle input is given. Therefore this area can not be tuned.