

# [POWER COMMANDER V]

**2009 Yamaha VMax**

**Installation Instructions**



## **PARTS LIST**

- 1 Power Commander
- 1 USB Cable
- 1 CD-ROM
- 1 Installation Guide
- 2 Power Commander Decals
- 2 Dynojet Decals
- 1 O2 controller
- 2 Velcro
- 1 Alcohol swab

**THE IGNITION MUST BE TURNED OFF BEFORE INSTALLATION!**

YOU CAN ALSO DOWNLOAD THE POWER COMMANDER SOFTWARE AND LATEST MAPS FROM OUR WEB SITE AT:  
[www.powercommander.com](http://www.powercommander.com)

**PLEASE READ ALL DIRECTIONS BEFORE STARTING INSTALLATION**

**Dynojet**

2191 Mendenhall Drive North Las Vegas, NV 89081 (800) 992-4993 [www.powercommander.com](http://www.powercommander.com)

# POWER COMMANDER V INPUT ACCESSORY GUIDE

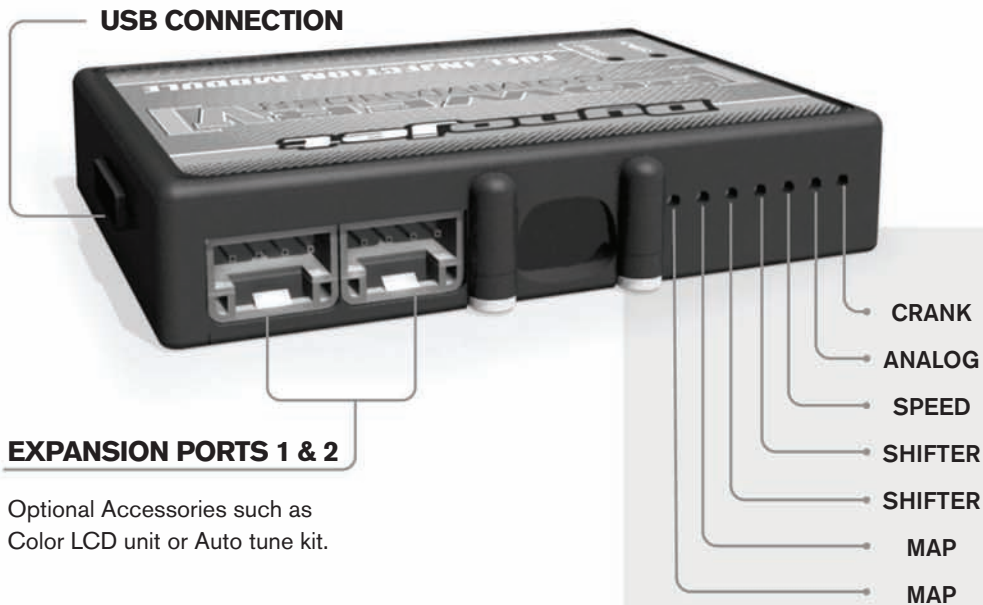

Optional Accessories such as Color LCD unit or Auto tune kit.

## Wire connections:

To input wires into the PCV first remove the rubber plug on the backside of the unit and loosen the screw for the corresponding input. Using a 22-24 gauge wire strip about 10mm from its end. Push the wire into the hole of the PCV until it stops and then tighten the screw. Make sure to reinstall the rubber plug.

NOTE: If you tin the wires with solder it will make inserting them easier.

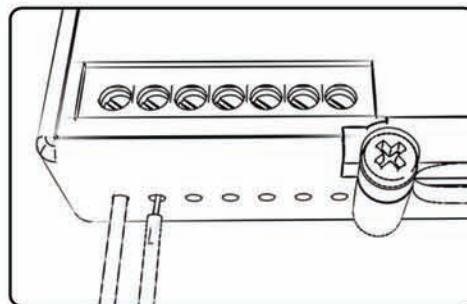

## ACCESSORY INPUTS

### Map -

The PCV has the ability to hold 2 different base maps. You can switch on the fly between these two base maps when you hook up a switch to the MAP inputs. You can use any open/close type switch. The polarity of the wires is not important. When using the Autotune kit one position will hold a base map and the other position will let you activate the learning mode. When the switch is "CLOSED" Autotune will be activated.

### Shifter-

These inputs are for use with the Dynojet quickshifter. Insert the wires from the Dynojet quickshifter into the SHIFTER inputs. The polarity of the wires is not important.

### Speed-

If your application has a speed sensor then you can tap into the signal side of the sensor and run a wire into this input. This will allow you to calculate gear position in the Control Center Software. Once gear position is setup you can alter your map based on gear position and setup gear dependent kill times when using a quickshifter.

### Analog-

This input is for a 0-5v signal such as engine temp, boost, etc. Once this input is established you can alter your fuel curve based on this input in the control center software.

### Crank-

Do **NOT** connect anything to this port unless instructed to do so by Dynojet. It is used to transfer crank trigger data from one module to another.

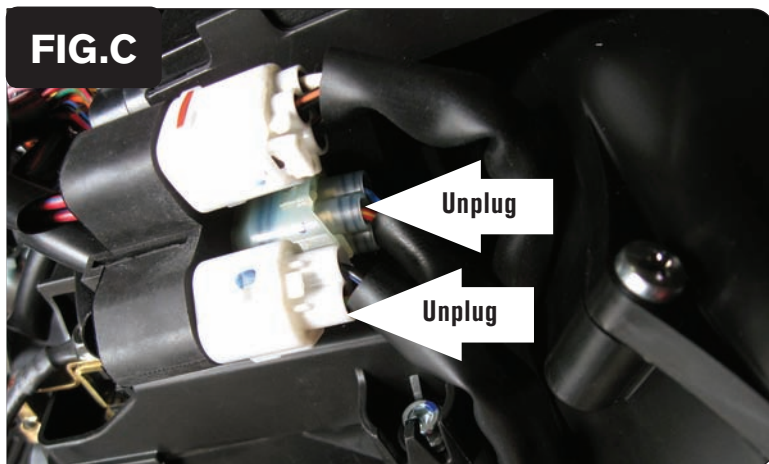
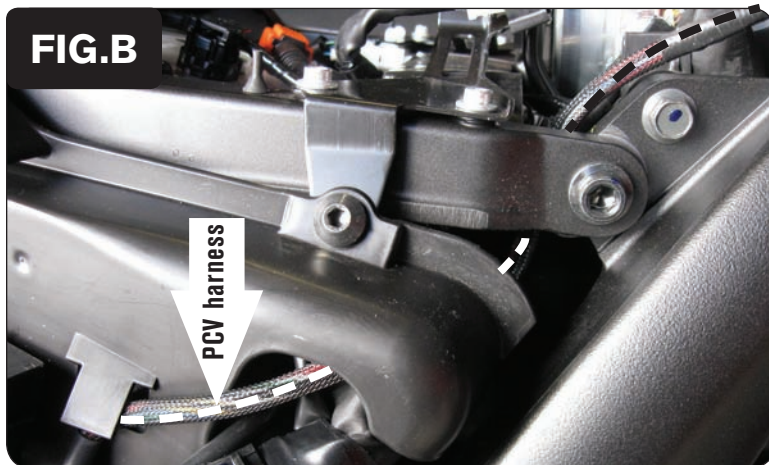
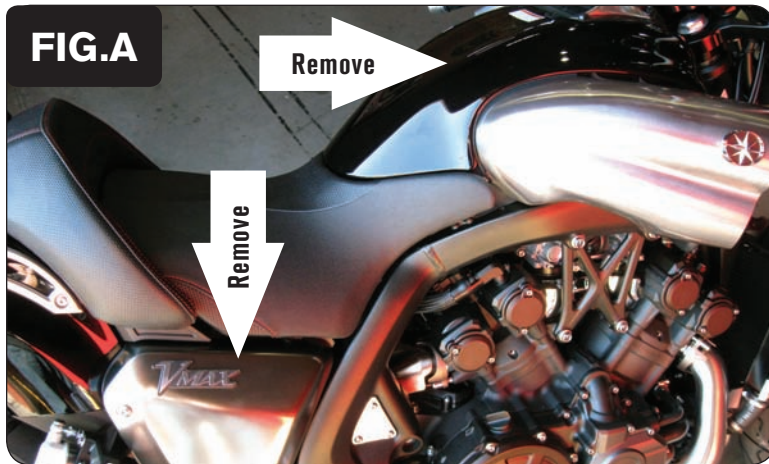

- 1 Remove the main seat.
- 2 Remove the cosmetic air box cover and side panel (Fig. A).
- 3 Lay the PCV under the right hand side cover temporarily.
- 4 Route the PCV harness inside of the subframe and go up towards the battery (Fig. B).

- 5 Unplug the connectors from the throttle bodies (Fig. C).

*These connectors are located to the right side of the ECU. One connector is a WHITE 3 pin and the other is a CLEAR 4 pin.*

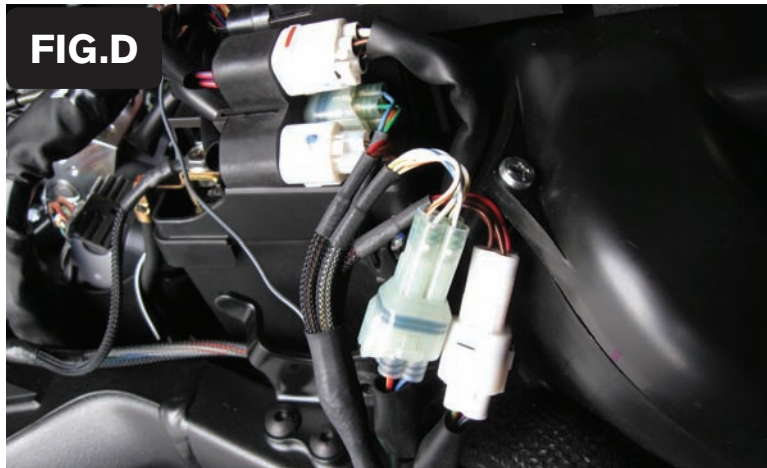

- 6 Plug the connectors from the PCV in-line of the stock wiring harness and throttle bodies (Fig. D)

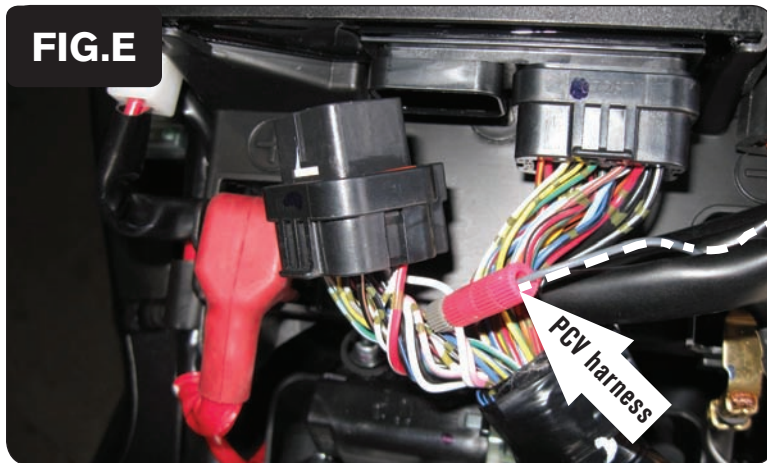

- 7 Using the supplied Posi-tap attach the GREY wire of the PCV harness to the WHITE wire of the small ECU plug (Fig. E).

*This is pin #5*

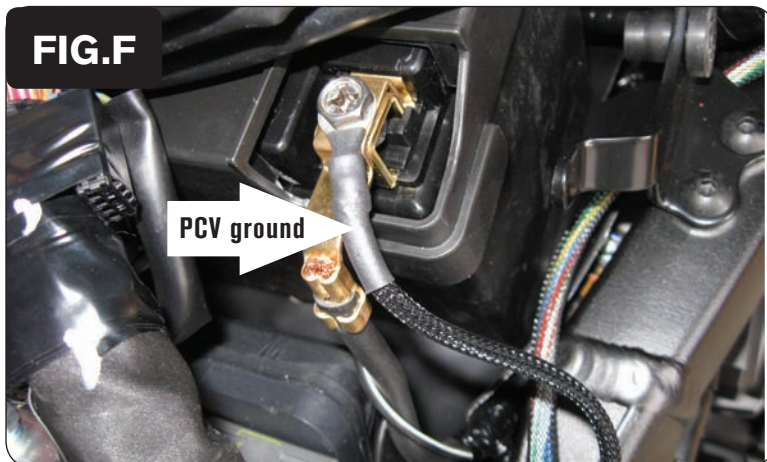
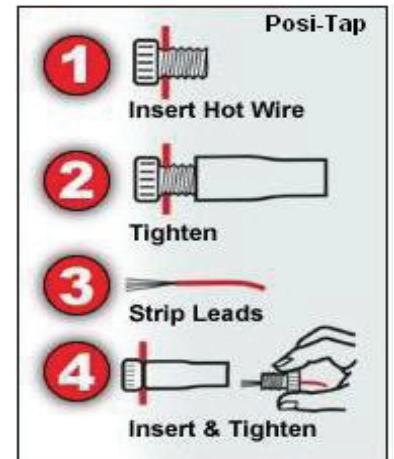

- 8 Attach the ground wire of the PCV to the negative side of the battery (Fig. F).

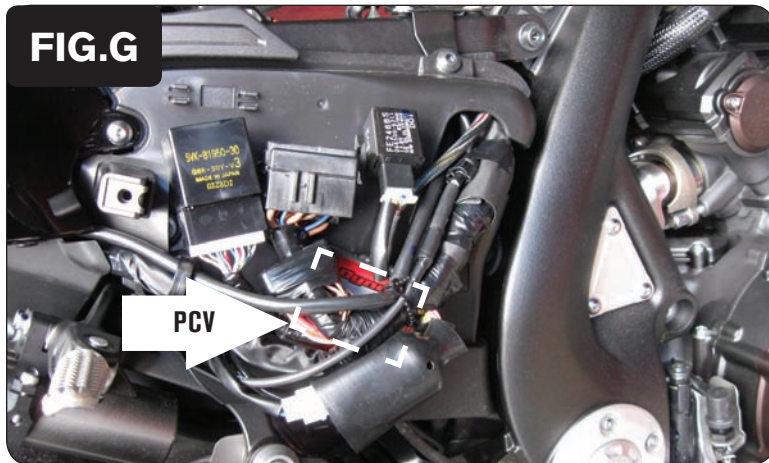

- 9 Using the supplied velcro secure the PCV to the plastic cover under the right hand side cover (Fig. G). Mount the PCV behind the stock electronics

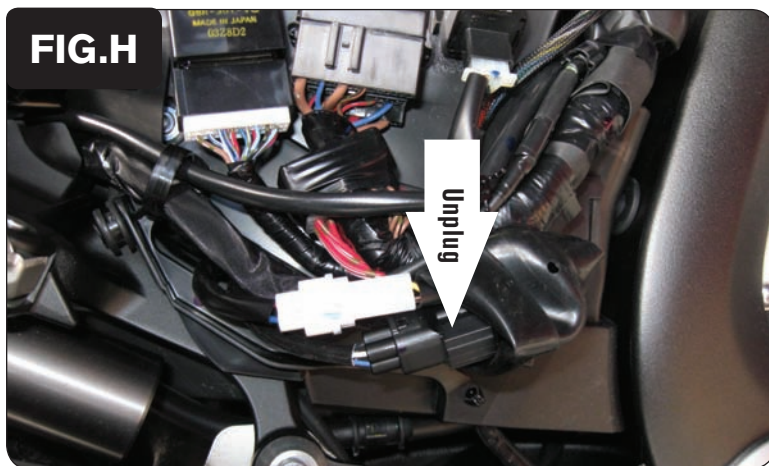

- 10 Locate the O2 sensor connection under the rubber boot on the right hand side of the bike (Fig. H). Unplug this connection.

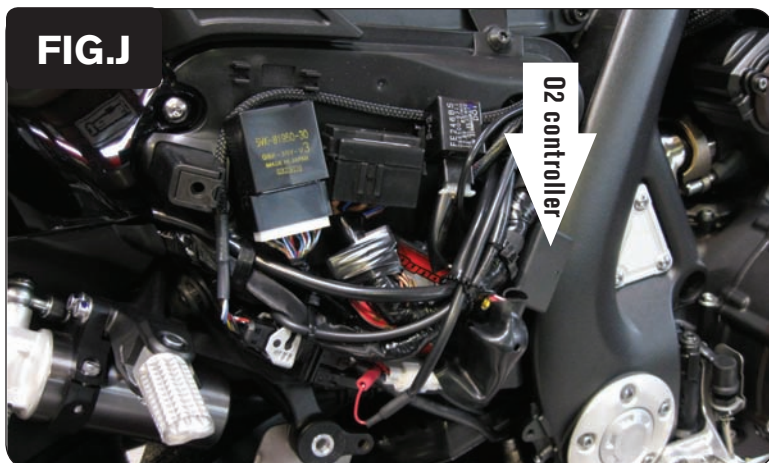

- 11 Plug the supplied O2 controller into the stock wiring harness (Fig. J).
- 12 Secure the O2 controller to the stock wiring harness  
*The stock O2 sensor will no longer be connected to anything at this time.*
- 13 Install covers and seat.

*Figure J shown with optional Auto tune system connected.*